

Installation Manual



Westinghouse
Security Systems

WSS5010
Version 1.0

Table of Contents

WSS5010 Control Panel Hookup Diagram

Section 1 - System Introduction

1.1	Specifications	1-1
1.2	Glossary	1-2
1.3	Additional Devices	1-3
1.3.1	Keypads	1-3
1.3.2	WSS5108 Eight Zone Expander Module	1-3
1.3.3	WSS5132-900 Wireless Receiver Module	1-3
1.3.4	WSS5204 Power Supply Output Module	1-4
1.3.5	WSS5208 Eight Low Current Output Module	1-4
1.3.6	WSS5580 Module	1-4
1.3.7	WSS5908 Audio Interface Module	1-5
1.3.8	WSS5400 Printer Module	1-5
1.3.9	LINKS 1000 Cellular Communicator	1-6
1.3.10	Cabinets	1-6
1.3.11	Backplates	1-8
1.4	Out of the Box	1-8

Section 2 - Getting Started

2.1	Installation Steps	2-1
2.2	Terminal Description	2-2
2.3	KEYBUS Operation and Wiring	2-3
2.4	Current Ratings - Modules and Accessories	2-4
2.5	Assigning Zones to Zone Expanders	2-4
2.6	Keypad Assignment	2-5
2.6.1	How to Assign Keypads	2-5
2.7	Enable Supervision	2-6
2.8	Removing Modules	2-6
2.9	Zone Wiring	2-7
2.9.1	Normally Closed (NC) Loops	2-7
2.9.2	Single End Of Line (EOL) Resistors	2-7
2.9.3	Double End Of Line (DEOL) Resistors	2-7
2.9.4	Fire Zone Wiring - 4-Wire Smoke Detectors	2-8
2.9.5	Fire Zone Wiring - 2-Wire Smoke Detectors	2-9
2.9.6	Keyswitch Zone Wiring	2-9
2.9.7	LINKS Supervisory	2-9
2.9.8	LINKS Answer	2-10

Section 3 - Keypad Commands

- 3.1 Access Codes 3-1
- 3.2 Arming 3-1
 - 3.2.1 Stay Arming 3-1
 - 3.2.2 Away Arming 3-1
- 3.3 Disarming 3-2
- 3.4 [*] Commands 3-2
 - [*]+[1] Zone Bypass/Reactivate Stay/Away Zones 3-2
 - [*]+[2] Trouble Display 3-3
 - [*]+[3] Alarm Memory 3-4
 - [*]+[4] Door Chime On/Off 3-4
 - [*]+[5] Programming Access Codes 3-4
 - [*]+[6] User Functions 3-6
 - [*]+[7] Utility Output Functions 3-7
 - [*]+[8] Installer Programming 3-7
 - [*]+[9] Arming Without Entry Delay 3-7
 - [*]+[0] Quick Exit 3-7
- 3.5 Function Keys 3-8

Section 4 - How to Program

- 4.1 How to Enter Installer Programming 4-1
- 4.2 Programming Decimal Data 4-1
- 4.3 Programming HEX Data 4-2
- 4.4 Programming Toggle Option Sections 4-2
- 4.5 Viewing Programming 4-2

Section 5 - Program Description

- 5.1 Zone Definitions 5-1
- 5.2 Zone Attributes 5-3
- 5.3 Communicator - Dialing 5-4
- 5.4 Communicator - Phone Numbers 5-4
- 5.5 Communicator - System Identifier Code 5-5
- 5.6 Communicator - Reporting Formats 5-5
 - 5.6.1 SIA 5-5
 - 5.6.2 Pager Format 5-6
- 5.7 Communicator - Reporting Codes 5-6
 - 5.7.1 Zone Alarm 5-6
 - 5.7.2 Zone Restoral 5-7
 - 5.7.3 Closings 5-7
 - 5.7.4 Openings 5-7
 - 5.7.5 Tamperers 5-8
 - 5.7.6 Priority/Emergency 5-8
 - 5.7.7 Maintenance 5-8
 - 5.7.8 Test Transmissions 5-9
 - 5.7.9 Wireless Maintenance 5-9
 - 5.7.10 Miscellaneous 5-9

5.8	Downloading	5-10
5.9	Zone Assignments	5-11
5.10	PGM Outputs	5-11
	5.10.1 PGM Output Options	5-12
	5.10.2 PGM Output Attributes	5-13
5.11	Telephone Line Monitor (TLM)	5-14
5.12	Siren Supervision	5-14
5.13	Test Transmission	5-15
5.14	Fire, Auxiliary, Panic Keys	5-15
5.15	Entry/Exit Delay Options	5-16
5.16	Event Buffer	5-16
	5.16.1 Viewing the Event Buffer through the LCD Keypad	5-17
	5.16.2 Stored Events	5-17
5.17	Swinger Shutdown	5-18
5.18	Transmission Delay	5-18
5.19	Keypad Backlighting	5-19
5.20	Arming/Disarming Options	5-19
5.21	Keypad Lockout	5-20
5.22	Keypad Blanking	5-20
5.23	Loop Response	5-20
5.24	LINKS 1000 Cellular Communicator	5-21
	5.24.1 Using LINKS 1000 as the Sole Communicator	5-21
	5.24.2 Using the LINKS as a Backup Communicator	5-21
	5.24.3 Using the LINKS as a Redundant Communicator	5-21
5.25	Wireless Expansion	5-21
	5.25.1 Adding Wireless Devices	5-22
	5.25.2 Wireless Device Placement Test	5-22
5.26	WSS5580 Module	5-23
5.27	On-Site Printer	5-23
5.28	Audio Interface Module	5-24
5.29	Default (Factory)	5-24
	5.29.1 Factory Default Main Panel (Hardware)	5-24
	5.29.2 Factory Default Main Panel (Software)	5-24
	5.29.3 Factory Default WSS5580 Module	5-24
	5.29.4 Factory Default WSS5132-900 Wireless Module	5-25
	5.29.5 Factory Default WSS5400 On-Site Printer Module	5-25
	5.29.6 Factory Default WSS5908 Audio Interface Module	5-25
5.30	Installer Lockout	5-25
5.31	Walk Test (Installer)	5-26
Appendix A - SIA Format		Appendix A - 1
Appendix B - How to Program the LCD Keypad		Appendix B - 1
Appendix C - List of Available ASCII Characters		Appendix C - 1
Index		Index - 1
UL Listed Commercial and Residential Installations		Inside Back Cover

Hookup Diagram

WSS5010 CONTROL PANEL

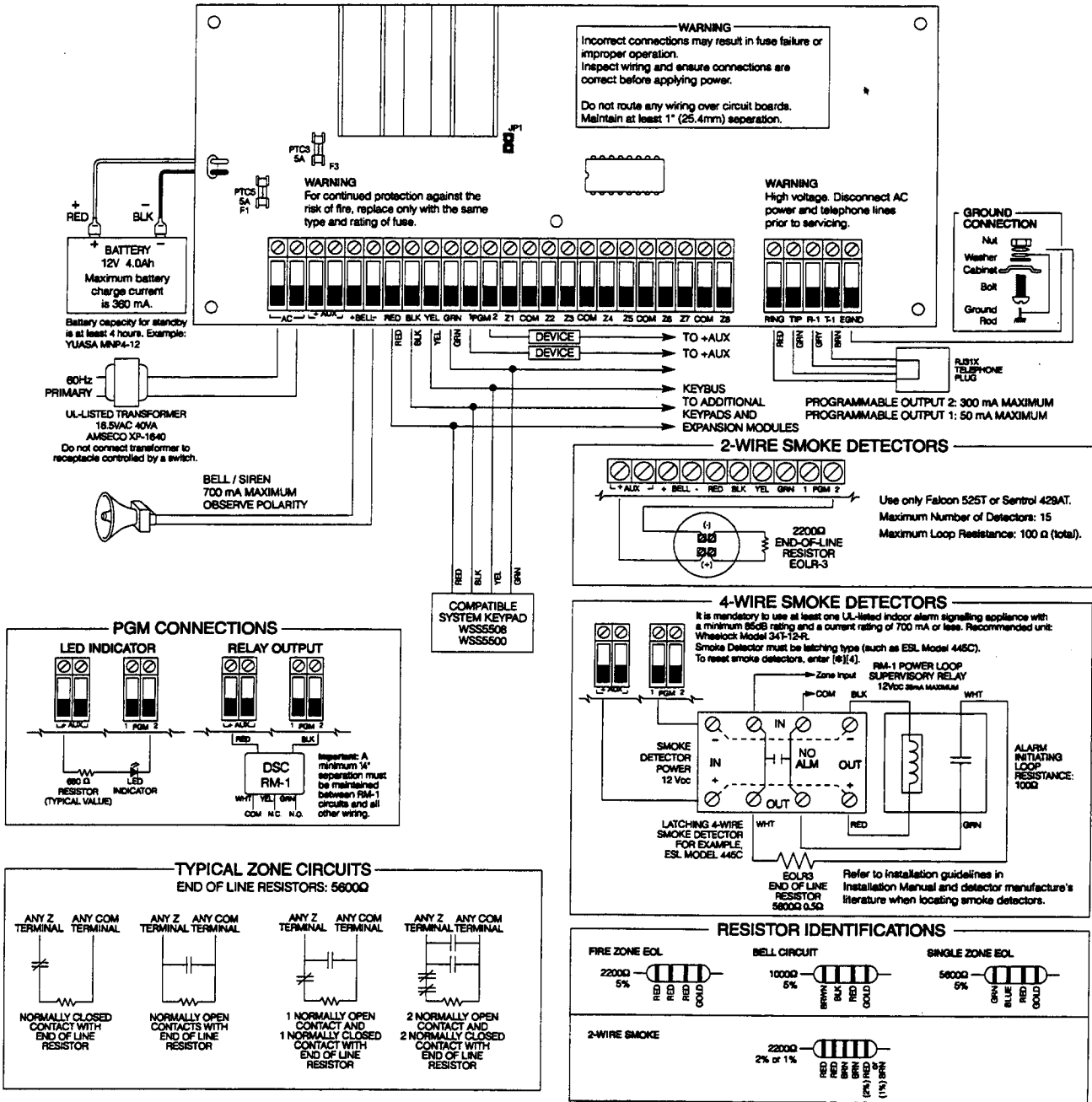

- Control Panel is suitable for the following UL installations:
- Household Fire and Grade A Household Burglary
 - Grade A Local I Grade B Central Station and Police Connect with basic line security
 - Grade C Central Station
 - Refer to installation manual

WARNING: Not to be removed by anyone except occupant.

Temperature Range: 0°C-49°C (32°F-120°F)
Maximum Humidity: 95% R.H.
Refer to the Installation and Instruction Manuals for complete operating instructions.

The WSS5010 (PC5010) is UL-listed for limited energy installations per NEC Article 780. Recognized limited energy cable should be used. Observe NEC wiring requirements and local codes defined by the authority having jurisdiction.

This equipment should be installed in accordance with ANS/NFPA 72-1993 (National Fire Protection Association, Batterymarch Park, Quincy MA, 02269). Printed information describing proper installation, operation, testing, maintenance, evacuation planning, and repair service is to be provided with this equipment.

Security detection devices that require power from the control panel must be UL-listed for the intended application and operate over the range of 11.6 - 12.6 Vdc (residential), 12.0 Vdc (commercial). The DS835 is a recommended UL-listed motion detector.

System Introduction

S E C T I O N 1

1.1 Specifications

Control Panel Specifications

Flexible Zone Configuration:

- 8 Fully Programmable Zones
- 37 Access Codes: 32 User, 1 System Master, 2 Master and 2 Duress
- Expandable to 32 Zones
- Hardwired expansion available using the WSS5108 Eight Zone Expansion Module
- Wireless expansion available using the WSS5132-900 Wireless Zone Expansion Module (up to 32 wireless zones, 900MHz, True Spread Spectrum Technology, Fully Supervised)
- Normally Closed, Single EOL or Double EOL zone supervision
- 2-Wire Smoke Zone
- 27 Zone Types, 7 Programmable Zone Options

Audible Alarm Output:

- Supervised Bell Output (current limited at 3 amps), 12 Vdc
- Steady or Pulsed Output

EEPROM Memory:

- Will not lose programming or system status on complete AC and Battery failure

Programmable Outputs:

- Up to 14 Programmable Voltage Outputs, 14 programmable options
- One High Current (300 mA) PGM output with 2 wire smoke detector capability on main panel
- Maximum Loop Current is 1.5 mA when the 2-wire smoke detector configuration is used
- One Low Current (50 mA) PGM output on main panel
- Eight Additional Low Current (50 mA) PGM outputs available using the WSS5208 module
- Four High Current (1 Amp) PGM outputs Available Using the WSS5204 module
- 1 WSS5204 Output Fully Supervised for Siren Output

Powerful 1 Amp Regulated Power Supply:

- 500 mA Auxiliary Supply, 12 Vdc
- Positive Temperature Coefficient (PTC) components replace fuses
- Supervision for loss of AC Power, Low Battery
- Internal Clock Locked to AC Power Frequency

Power Requirements:

- Transformer = 16.5 VAC, 40VA
- Battery = 12 volt 4 Ah minimum rechargeable sealed lead acid

Remote Keypad Specifications:

- 2 Different Keypads Available:
 - WSS5508 8 Zone LED Keypad
 - WSS5500 LCD Alphanumeric Keypad
- Connect up to 8 Keypads
- Four Wire (Quad) Connection to KEYBUS
- Built in Piezoelectric Buzzer

Digital Communicator Specifications:

- Supports SIA Format
- Event Initiated Personal Paging
- 3 Programmable Phone Numbers
- 1 Account number
- Supports LINKS 1000 Cellular Communication
- DTMF and Pulse Dialing
- DPDT Line Seizure
- Anti-jam Feature
- Split Reporting of Selected Transmissions to Each Telephone Number

System Supervision Features

The WSS5010 continuously monitors a number of possible trouble conditions including:

- AC Power Failure
- Fire Trouble
- Low Battery Condition
- Loss of Internal Clock
- Tamper by Zone
- Module Fault (Supervisory or Tamper)
- Trouble by Zone
- Telephone Line Trouble
- Bell Output Trouble
- AUX Power Supply Fault
- Failure to Communicate

False Alarm Prevention Features

- Audible Exit Delay
- Urgency on Entry Delay
- Swinger Shutdown
- Communication Delay
- Audible Exit Fault
- Quick Exit
- Recent Closing Transmission

Additional Features

- Keypad Activated Alarm Output and Communicator Test
- Keypad Lockout
- Audio Capability using the WSS5908 Audio Interface Module which allows local intercom and Central Station 2-Way Listen in.
- All modules connect to the system via a four wire KEYBUS up to 1000'/330m from main panel
- Event Buffer can be printed using WSS5400 RS232 Serial Interface module
- Supports the WSS5580 Voice Prompt Module with Automation/Lighting Control
- 128 Event Buffer, Time and Date Stamped
- Upload/Download Capability

1.2 Glossary**• Event Buffer**

The event buffer automatically logs events as they occur on the system. The buffer will store the last 128 events that occurred on the system. All events are stored with time and date stamp.

• Programmable Outputs

Programmable outputs are voltage outputs which can be programmed to activate when certain conditions occur on the system. These outputs can be used to drive low current devices or relays if higher current is required.

- **Module**
All keypads, zone expanders and output boards are considered modules.
- **KEYBUS**
The KEYBUS is the four wire cable to which all modules are connected. The KEYBUS is used by the panel to communicate with all modules on the system.
- **Function Key**
Every keypad has 5 Function Keys to allow commonly used commands to be executed by pressing one button. By pressing and holding the function key for two seconds the user can execute the following commands; Stay Arm, Away Arm, Door Chime Enable/Disable, Smoke Detector Reset and Quick Exit. (See Section 3.5 "Function Keys").

1.3 Additional Devices

1.3.1 Keypads

A maximum of eight (8) keypads can be connected to the control panel and can be any combination of the following listed.

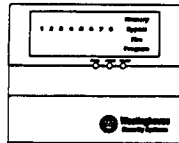

WSS5508

8 zone LED keypad with function keys

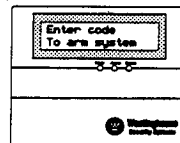

WSS5500

LCD keypad with function keys

1.3.2 WSS5108 Eight Zone Expander Module

Eight zone expander module can be used to increase the number of zones on the system. Up to 3 modules can be connected to increase the system zones to a maximum of 32.

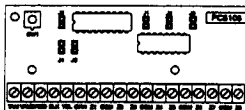

1.3.3 WSS5132-900 Wireless Receiver Module (This device is not UL Listed)

The WSS5132-900 Wireless Receiver module can be used to connect up to 32 wireless devices. All devices are spread spectrum, 900 MHz, fully supervised and use standard 'AAA' or 'AA' alkaline batteries (See Section 5.27 "Wireless Expansion").

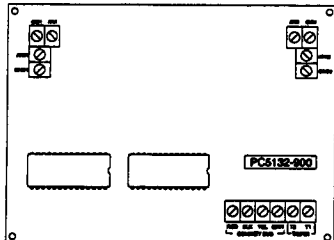

Two additional devices are available. They are as follows:

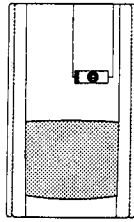

WSSPIR

Wireless Motion Detector

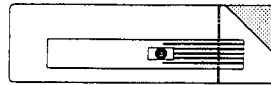

WSSUTX

Wireless Universal Transmitter

WSSPIR Wireless Motion Detector (This device is not UL Listed)

The wireless Motion Detector can be used in conjunction with the WSS5132-900 Wireless Receiver to include wireless space protection. The unit comes with four 'AAA' batteries.

WSSUTX Wireless Universal Transmitter (This device is not UL Listed)

The wireless Universal Transmitter can be used in conjunction with the WSS5132-900 Wireless Receiver module to add wireless door or window contacts. The Universal Transmitter comes with three 'AAA' batteries and has built-in contacts. The unit also provides terminals for connecting hardwire contacts.

1.3.4 WSS5204 Power Supply Output Module (This device is not UL Listed)

The WSS5204 can provide up to 1 Amp of additional power for modules or devices connected to the control panel. The module requires a 16.5 volt AC 40 VA transformer and 4 AH battery. In addition, the module provides 4 programmable high current voltage outputs. Each output is individually programmable with 14 different output options available (See Section 5.10 "PGM Outputs").

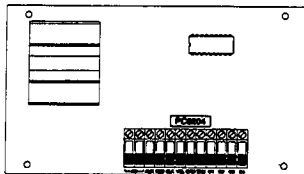

1.3.5 WSS5208 Eight Low Current Output Module

Adds eight low current outputs (50 mA) to the control. Each output is individually programmable with 14 different output options available (See Section 5.10 "PGM Outputs").

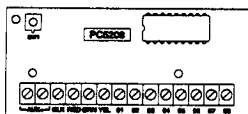

1.3.6 WSS5580 Module (This device is not UL Listed)

This WSS5580 module will turn any touch tone phone into a fully functional keypad. The module also includes a built-in interface to control up to 32 line carrier type devices for lighting and temperature control (See Section 5.28 "WSS5580 Module").

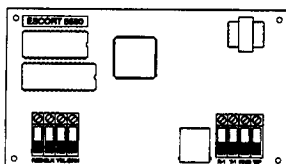

1.3.7 WSS5908 Audio Interface Module (This device is not UL Listed)

The WSS5908 Audio Interface module is a simple way to incorporate paging, intercom, baby listen-in, background music and door answer to the WSS5010 control panel. The module also has built-in two-way voice capability for central station (See Section 5.30 "Audio Interface Module").

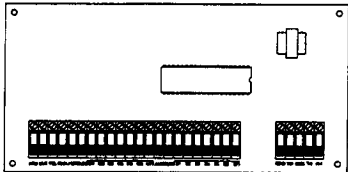

Three additional devices are available. They are as follows:

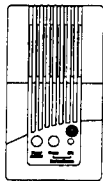

WSS5903
Intercom Audio Station

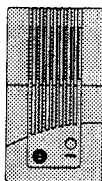

WSS5903 EXT
Door Box Audio Station

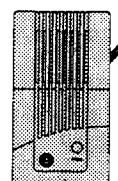

WSS5903 EXT/R
Door Box Audio Station

WSS5903 Intercom Audio Station (This device is not UL Listed)

The WSS5903 Intercom Audio Station can be used in conjunction with the WSS5908 Audio Interface Module.

WSS5903 EXT Door Box Audio Station (This device is not UL Listed)

The WSS5903 EXT Door Box Audio Station can be used in conjunction with the WSS5908 Audio Interface Module.

WSS5903 EXT/R Door Box Audio Station (This device is not UL Listed)

The WSS5903 EXT/R Door Box Audio Station can be used in conjunction with the WSS5908 Audio Interface Module. The Door Box contains a relay so the normal door bell can be used instead of the internal one generated by the WSS5908 module.

1.3.8 WSS5400 Printer Module (This device is not UL Listed)

This WSS5400 Printer Module will allow the panel to print out all events that occur on the system to any serial printer. All events will be printed with the time, date and the event that occurred (See Section 5.29 "On-site Printer").

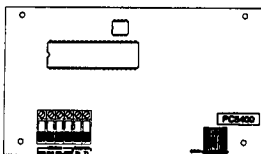

1.3.7 WSS5908 Audio Interface Module (This device is not UL Listed)

The WSS5908 Audio Interface module is a simple way to incorporate paging, intercom, baby listen-in, background music and door answer to the WSS5010 control panel. The module also has built-in two-way voice capability for central station (See Section 5.30 "Audio Interface Module").

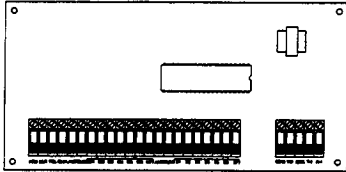

Three additional devices are available. They are as follows:

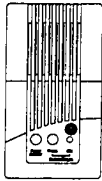

WSS5903
Intercom Audio Station

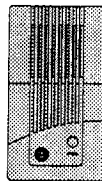

WSS5903 EXT
Door Box Audio Station

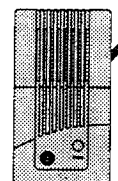

WSS5903 EXT/R
Door Box Audio Station

WSS5903 Intercom Audio Station (This device is not UL Listed)

The WSS5903 Intercom Audio Station can be used in conjunction with the WSS5908 Audio Interface Module.

WSS5903 EXT Door Box Audio Station (This device is not UL Listed)

The WSS5903 EXT Door Box Audio Station can be used in conjunction with the WSS5908 Audio Interface Module.

WSS5903 EXT/R Door Box Audio Station (This device is not UL Listed)

The WSS5903 EXT/R Door Box Audio Station can be used in conjunction with the WSS5908 Audio Interface Module. The Door Box contains a relay so the normal door bell can be used instead of the internal one generated by the WSS5908 module.

1.3.8 WSS5400 Printer Module (This device is not UL Listed)

This WSS5400 Printer Module will allow the panel to print out all events that occur on the system to any serial printer. All events will be printed with the time, date and the event that occurred (See Section 5.29 "On-site Printer").

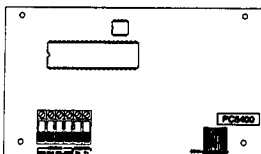

1.3.9 LINKS 1000 Cellular Communicator (This device is not UL Listed)

The LINKS 1000 Cellular Communicator provides an efficient, cost-effective method for adding cellular back up. The unit comes in its own cabinet with antenna and requires a separate battery and transformer (See Section 5.26 "LINKS 1000 cellular communicator").

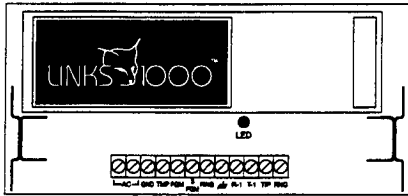

1.3.10 Cabinets

Several different cabinets are available for the WSS5010 modules. They are as follows:

WSS5003C Cabinet

Main control cabinet for the WSS5010 main panel. Dimensions 288mm x 298mm x 78mm / 11.3" x 11.7" x 3" approximately.

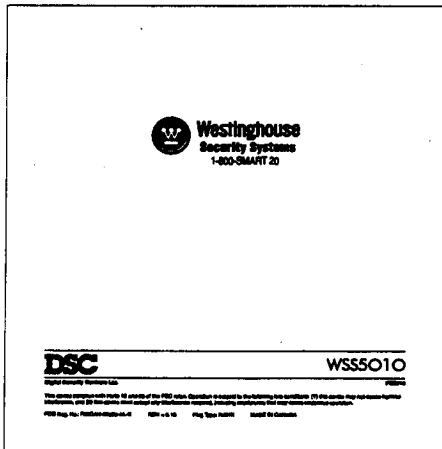

WSS5002C Cabinet

Cabinet to house the WSS5204 Power Supply Output Module. Dimensions 213mm x 235mm x 78mm / 8.4" x 9.25" x 3" approximately.

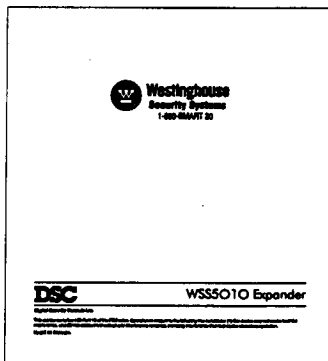

WSS5004C Cabinet

Cabinet to house the WSS5580 Module and WSS5400 Printer Module. Dimensions 229mm x 178mm x 65mm / 9" x 7" x 2.6" approximately.

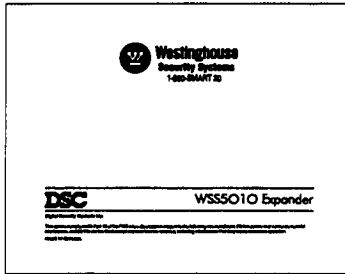

WSS5001C Cabinet

Cabinet to house the WSS 5108 Zone Expander Module and the WSS5208 Eight Low Current Output Module. Dimensions 153mm x 122mm x 38mm / 6" x 4.8" x 1.5" approximately.

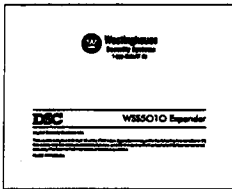

WSS5001CP Cabinet

Plastic cabinet to house the WSS5108 Zone Expander Module and the WSS5208 Eight Low Current Output Module. Dimensions 146mm x 105mm x 25.5mm / 5.75" x 4.2" x 1" approximately.

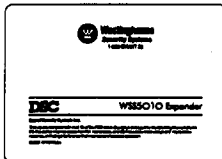

WSS5132C Cabinet

Cabinet to house the WSS5132-900 Wireless Receiver Module. Dimensions 165mm x 143mm x 38mm / 6.5" x 5.625" x 1.5" approximately.

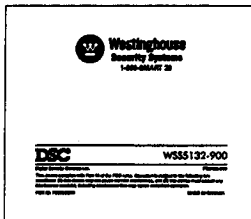

1.3.11 Backplates

There are two different backplates available for keypads to locate an Audio Station next to the keypad. They are as follows:

WSS55BP1 Backplate

This backplate is to be used when an Audio Station is to be located next to a keypad. Dimensions 208mm x 115mm x 18mm / 8.2" x 4.5" x 0.25" approximately.

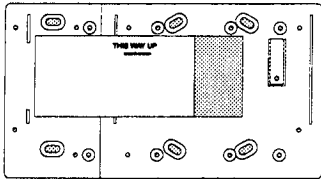

WSS55BP2 Backplate

This backplate is to be used when an Audio Station is to be located next to a keypad. In addition the backplate will allow you to mount a WSS5108 Zone Expander Module or the WSS5208 Eight Low Current Output Module. Dimensions 208mm x 115mm x 18mm / 8.2" x 4.5" x 0.7" approximately.

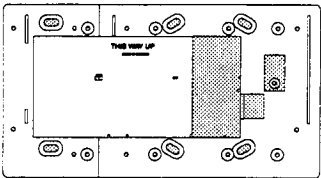

1.4 Out of the Box

You should find the following equipment included in your system. Verify each of the components is included:

- one WSS5010 main control cabinet
- one WSS5010 main control circuit board
- one WSS5508 keypad
- one Installation Manual
- one Programming Worksheet Manual
- one LED End User Manual
- one hardware pack consisting of:
 - 5 plastic circuit board standoffs
 - 16 5600 ohm (5.6K) resistors
 - 1 2200 ohm (2.2K) resistor
 - 1 1000 ohm (1K) resistor

Getting Started

S E C T I O N 2

The following sections provide a complete description of how to wire and configure devices and zones.

2.1 Installation Steps

The following steps are provided to assist with the installation of the panel. It is suggested that you read over this section briefly to get an overall understanding of the order of installation. Once this is done carefully work through each step. Working from this plan will help reduce problems and reduce the overall installation time required.

Step 1 Create a Layout

Draw a rough sketch of the building and include all alarm detection devices, zone expanders, keypads and all other modules that are required.

Step 2 Mounting the Panel

Locate the panel in a dry area, preferably located near an unswitched AC power source and the incoming telephone line. **Before attaching the cabinet to the wall be sure to press the five circuit board mounting studs into the cabinet from the back.**



Complete all wiring before applying AC or connecting the battery.

Step 3 Wiring the KEYBUS (Section 2.3)

Wire the KEYBUS to each of the modules following the guidelines provided.

Step 4 Assigning Zones to Zone Expanders (Section 2.5)

If zone expander modules are being used the modules must be configured so the panel knows which zones are assigned to each expander. Follow the guideline provided to assign zones to expanders.

Step 5 Zone Wiring (Section 2.9)

Power down the control panel and complete all zone wiring. Follow the guidelines provided in Section 2.9 to connect zones using normally closed loops, single EOL resistor, double EOL resistors, Fire zones and Keyswitch Arming zones.

Step 6 Completing Wiring

Complete all other wiring including bells or sirens, phone line connections, ground connections or any other wiring necessary. Follow the guidelines provided in Section 2.2 "Terminal Descriptions".

Step 7 Power up the Control

Once all zone wiring and KEYBUS wiring is complete, power up the control panel.



The panel will not power up if only the battery is connected.

Step 8 Keypad Assignment (Section 2.6)

Keypads must be assigned to different slots to be properly supervised. Follow the guideline provided in Section 2.6 to assign keypads.

Step 9 Enabling Supervision (Section 2.7)

After all modules have been wired to the KEYBUS, supervision must be enabled. Once supervision is enabled, the panel will be able to indicate module communication faults. Follow the guidelines provided in Section 2.7.

Step 10 Programming the System (Sections 4 and 5)

Section 4.0 provides a complete description of how to program the panel. Section 5.0 contains complete descriptions of the various programmable features, what options are available and how the options function. The Programming Work Sheets should be filled out completely before attempting to program the system.

Step 11 Testing the System

Test the panel completely to ensure that all features and functions are operating as programmed.

2.2 Terminal Descriptions

AC Terminals - AC

The panel requires a 16.5 volt, 40 VA transformer. Connect the transformer to an unswitched AC source and connect the transformer to these terminals.

! Do not connect the transformer until all other wiring is complete.

Battery Connection

The battery is used to provide back up power in the event of an AC power failure and to provide additional current when the panel demands exceed the power output of the transformer, such as when the panel is in alarm.

! Do not connect the battery until all other wiring is complete.

Connect the RED battery lead to the positive of the battery, the BLACK battery lead to the negative.

Auxiliary Power Terminals - AUX+ and GND

These terminals provide up to 500 mA of additional current at 12 Vdc (**rated 11.6 - 12.6 Vdc for UL residential applications**) for devices requiring power. Connect the positive side of any device requiring power to the AUX+ terminal, the negative side to GND. The AUX output is protected; if too much current is drawn from these terminals (wiring short) the panel will temporarily shut off the output, until the problem is corrected.

Bell Output Terminals - BELL+ and BELL-

These terminals provide up to 3 Amps of current at 12 Vdc (**rated 11.6 - 12.6 Vdc for UL residential applications**) (with stand-by battery; 700 mA continuous) for powering bells, sirens, strobes or other warning type equipment. Connect the positive side of any alarm warning device to BELL+, the negative side to BELL-. The BELL output is protected; if too much current is drawn from these terminals (wiring short) the BELL fuse will open.

The Bell output is supervised. If no alarm warning device is being used connect a 1000 ohm resistor across BELL+ and BELL- to prevent the panel from displaying a trouble condition (*See Section 3.4 "[*] Commands, [*][2]"*).

KEYBUS Terminals - RED, BLK, YEL, GRN

The KEYBUS is used by the panel to communicate talk with modules and by modules to communicate with the panel. Each module has four KEYBUS terminals that must be connected to the four KEYBUS terminals on the panel. For more information, see Section 2.3 "KEYBUS Operation and Wiring".

Programmable Outputs - PGM1 and PGM2

Each PGM output is an open collector switch to ground. That is, when the PGM output is activated by the panel the terminal will switch to ground.

PGM1 can sink up to 50 mA of current to activate LEDs or a small buzzer. Connect the positive side of the LED or buzzer to AUX+, the negative side to PGM1. If more than 50 mA of current is required a relay must be used. Refer to the following diagram:

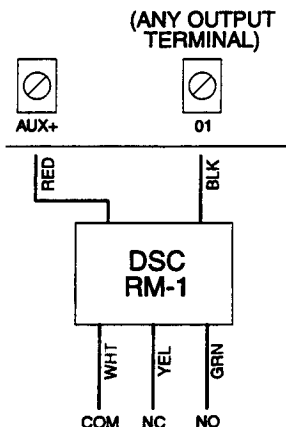

PGM2 operates similar to PGM1.

Zone Input Terminals - Z1 to Z8

Each detection device must be connected to a zone on the control. It is suggested that each zone have one detection device however it is possible to wire multiple detection devices to the same zone.

For zone wiring specifics, see Section 2.9 "Zone Wiring".

Telephone Connection Terminals - TIP, RING, T-1, R-1

If a telephone line is required for central station communication or downloading connect an RJ-31X jack in the following manner:

- RING - Red Wire telephone company
- TIP - Green Wire incoming line from
- R-1 - Grey Wire house telephone(s)
- T-1 - Brown Wire outgoing line to

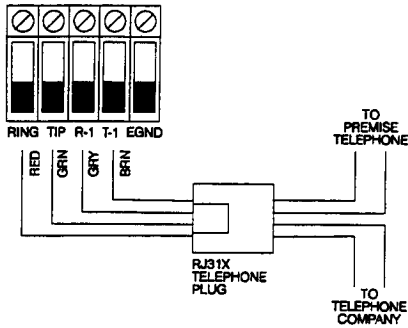

! *Ensure the plugs and jacks meet the dimension, tolerance and metallic plating requirements of 47 C.F.R. Part 68, SubPart F. For proper operation there must be no other telephone equipment connected between the control panel and the telephone company facilities. Do not connect the alarm panel communicator to telephone lines intended for use with a FAX machine. These lines may incorporate a voice filter which disconnects the line if anything other than FAX signals are detected, resulting in incomplete transmissions.*

2.3 KEYBUS Operation and Wiring

The KEYBUS is used by the panel to communicate with all modules connected and by the modules to talk to the panel. The RED and BLK terminals are used to provide power while YEL and GRN are clock and data.

! *The 4 KEYBUS terminals of the panel must be connected to the 4 KEYBUS terminals or wires of all modules.*

The following conditions apply:

- KEYBUS should be run in minimum 22 gauge quad (0.5mm), two pair twist preferred
- the modules can be home run to the panel, connected in series or can be T-tapped
- any module can be connected anywhere along the KEYBUS, you do not need a separate KEYBUS wire run for keypads, zone expanders etc.
- no module can be more than 1,000'/330m (in wire length) from the panel
- shielded wire is not necessary unless wires are run in an area that may present excessive RF noise or interference

Example of KEYBUS Wiring

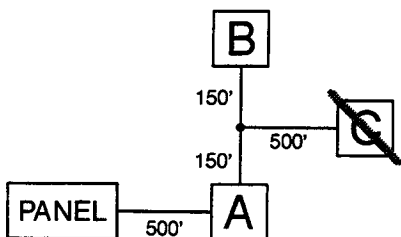

NOTE: Module (A) is wired correctly as it is within 1,000'/330m of the panel, in wire distance.
 Module (B) is wired correctly as it is within 1,000'/330m of the panel, in wire distance
 Module (C) is NOT wired correctly as it is further than 1,000'/330m from the panel, in wire distance.

2.4 Current Ratings - Modules and Accessories

In order for the WSS5010 system to operate properly, the power output capabilities of the main control and expansion devices must not be exceeded. Use the data presented below to ensure that no part of the system is overloaded and cannot function properly.

System Outputs (all 12 Vdc)

- WSS5010
 - +AUX: 500 mA. Includes one keypad. Subtract for each additional keypad, expansion module and accessory connected to VAUX or KEYBUS.
 - BELL: 700 mA. Continuous Rating.
 - 3.0 A. Short Term. Available only with stand-by battery connected.
- WSS5204
 - VAUX: 1.0 A. Continuous Rating. Subtract for each device connected.
 - 3.0 A. Short Term. Available only with stand-by battery connected.
- WSS5208
 - VAUX: 250 mA. Subtract for each device connected. Subtract the total load on this terminal from the WSS5010 VAUX/KEYBUS output.
- WSS5108
 - VAUX: 100 mA. Subtract for each device connected. Subtract the total load on this terminal from the WSS5010 VAUX/KEYBUS output.

WSS5010 Device Ratings (@ 12 Vdc)

- WSS5500 LCDKeypad: 50 mA
- WSS5508 LED Keypad: 45 mA
- WSS5108 Zone Module: 35 mA
- WSS5204 Output Module: 20 mA
- WSS5208 Output Module: 50 mA
- WSS5132-900 Wireless Module: 125 mA
- WSS5580 Module: 150 mA
- WSS5908 Audio Interface Module: 65 mA
- WSS5903 Intercom Audio Station: 20 mA
- WSS5903 EXT Door Box Audio Station: 20 mA
- WSS5903 EXT/R Door Box Audio Station: 35 mA
- WSS5400 Serial Printer Module: 62 mA

Other Devices

Read the manufacturer's literature carefully to determine the maximum current requirement (during activation or alarm) and use this value for loading calculations. Do not allow connected devices to exceed the system capabilities during any possible operational mode.

2.5 Assigning Zones to Zone Expanders

The main panel contains zones 1 to 8. Additional zone expanders may be added to increase the number of zones on the system. Each zone expander consists of two groups of 4 zones and each group must be configured to assign the specific zones to the expander. This is done by setting the jumpers located on the expander to the proper settings.

! Before a zone expander will work properly the jumpers must be set so the panel can determine the correct zone assignment.

Following are the jumper settings for different zone assignments:

Expander Zones	Jumpers			System Zones Assigned
Group A (Zones 1-4)	J1	J2	J3	
Group B (Zones 5-8)	J4	J5	J6	
	ON	ON	ON	Zones Disabled
	OFF	ON	ON	Zones Disabled
	ON	OFF	ON	Zones 9 - 12
	OFF	OFF	ON	Zones 13 - 16
	ON	ON	OFF	Zones 17 - 20
	OFF	ON	OFF	Zones 21 - 24
	ON	OFF	OFF	Zones 25 - 28
	OFF	OFF	OFF	Zones 29 - 32

The following is a diagram of the zone expander and where the jumper switches are located.

! *There are two sets of jumpers, one set for the first 4 zones of the expander and one set for the other 4 zones.*

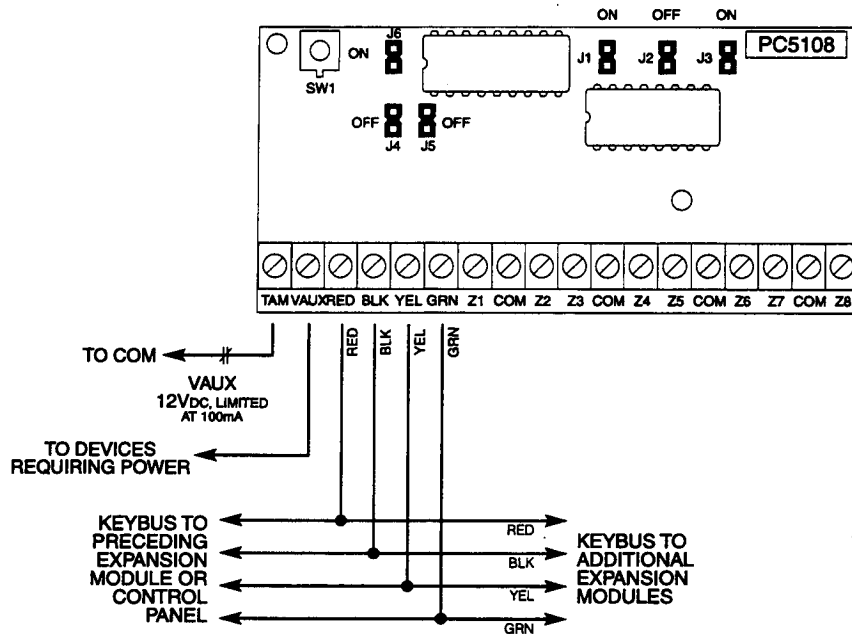

In the above diagram the jumpers settings shown indicate the first group of four zones of the expander will be zones 9 to 12 and the second group of 4 zones will be 13 to 16.

A group of zones can be disabled if they are not required for the installation.

2.6 Keypad Assignment

There are 8 available slots for keypads. WSS5508 keypad by default are always assigned to slot 1 while the WSS5500 is always assigned to slot 8. Keypads can each be assigned to a different slot (1 to 8) which offers two advantages. The panel can supervise the keypad connection to indicate a trouble condition if it is removed.

2.6.1 How to Assign Keypads

! *All keypad assignment must be done individually on each keypad on the system.*

To assign a keypad to a slot, enter the following:

Step 1 — Enter Installer Programming

Step 2 — Press [000] for Keypad Programming

Step 3 — Press [0] for Slot Assignment

Enter a two digit number to specify the system and slot assignment.

1st digit Enter 1

2nd digit Enter 1 to 8 for Slot Assignment

Press the [#] key twice to exit programming. Continue this procedure at each keypad until all have been assigned to the correct slot.

2.7 Enable Supervision

Once all the KEYBUS connections have been made, supervision must be enabled so the panel can indicate a trouble if a module is removed from the system.

To enable supervision, enter the following at any keypad:

Step 1 - Press [*] [8] [Installer Code] to enter Installer Programming.

Step 2 - Press [902] to enable supervision. The panel will automatically search for all modules on the system. Once the search (it will take about 1 minute) is complete enter the following to confirm the modules on the system.

Step 3 - Press [903] to display all modules.

Zone lights will be turned on according to what modules the panel has found on the system. The LCD keypad will allow you to scroll through the modules. Refer to the following chart:

Light [1]	Keypad 1 present
Light [2]	Keypad 2 present
Light [3]	Keypad 3 present
Light [4]	Keypad 4 present
Light [5]	Keypad 5 present
Light [6]	Keypad 6 present
Light [7]	Keypad 7 present
Light [8]	Keypad 8 present
Light [9]	Zones 9 to 12 present
Light [10]	Zones 13 to 16 present
Light [11]	Zones 17 to 20 present
Light [12]	Zones 21 to 24 present
Light [13]	Zones 25 to 28 present
Light [14]	Zones 29 to 32 present
Light [15]	N/A (not used)
Light [16]	N/A (not used)
Light [17]	Module WSS5132-900 present
Light [18]	Module WSS5208 present
Light [19]	Module WSS5204 present
Light [20]	Module WSS5400 present
Light [21]	Module WSS5908 present
Light [22]	N/A
Light [23]	N/A
Light [24]	WSS5580 module present

If a module is connected but does not show as being present, it may be due to any of the following reasons:

- it is not connected to the KEYBUS
- if there is a KEYBUS wiring problem
- if the module is more than 1,000'/330m from the panel
- if the module does not have enough power
- if the WSS5132-900 does not have any devices added

2.8 Removing Modules

If a module is no longer required on the system the panel must be told to no longer supervise the module. To do this remove the module from the KEYBUS and perform the Enable supervision function again (*See Section 2.7 "Enable Supervision"*). The panel will see the module has been removed and will no longer supervise it.

2.9 Zone Wiring

There are several different ways in which zones may be wired, depending on the programming options selected. The following is a description of each individually supervised.

! *Any zone defined as Fire, 24 Hour Links Supervisory and Links Answer (See Section 5.1 "Zone Definitions") will automatically require a single End of Line (EOL) resistor regardless of which type of zone wiring supervision is selected. When reconfiguring the zone supervision from a non-default setting, such as DEOL to EOL/ NC to DEOL/disabling zones 1-8 while open or in trouble, the system should be powered down completely and powered up again.*

2.9.1 Normally Closed (NC) Loops

Wire all zones according to the following diagrams:

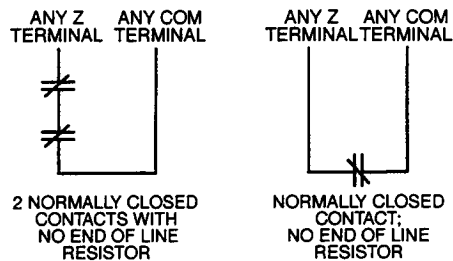

! *This option can only be selected if Normally Closed (NC) detection devices or contacts are being used.*

2.9.2 Single End Of Line (EOL) Resistors

Wire all zones according to the following diagrams:

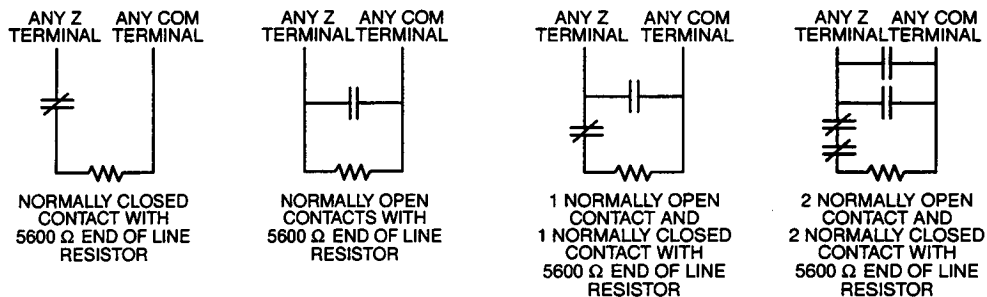

! *This option can be selected if either Normally Closed (NC) or Normally Open (NO) detection devices or contacts are being used.*

2.9.3 Double End of Line (DEOL) Resistors

! *Important Note*
Double End of Line resistors must be enabled in the WSS5010 for the wireless zones to be supervised. If normally Closed or Single EOL resistors are selected the WSS5010 will not be able to supervise the wireless devices.
If a wireless device stops sending a supervisory signal (the unit stops functioning) the panel will not indicate a supervisory trouble condition unless Double EOL supervision is used.
In addition, all hardwire zones must be wired for Double EOL resistors.

Double EOL loops allow the panel to determine if the zone is in alarm, tampered or faulted. Wire the zones according to the following diagram:

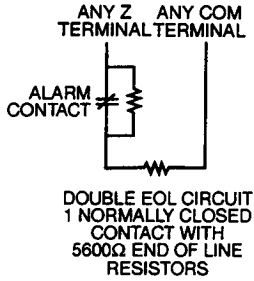

! *This option can only be selected if Normally Closed (NC) detection devices or contacts are being used. Only one NC contact can be connected to each zone, multiple detection devices or contacts on one loop is not allowed.*

The following chart shows the status of the zone under certain conditions:

Loop Resistance	Loop Status
5600Ω (contact closed)	Secure
11200Ω (contact open)	Violated
0Ω (shorted wire, loop shorted)	Fault
Infinite (broken wire, loop open)	Tamper

2.9.4 Fire Zone Wiring - 4 wire Smoke Detectors

All zones defined as Fire (See Section 5.1 "Zone Definitions") must be wired according to the following diagram:

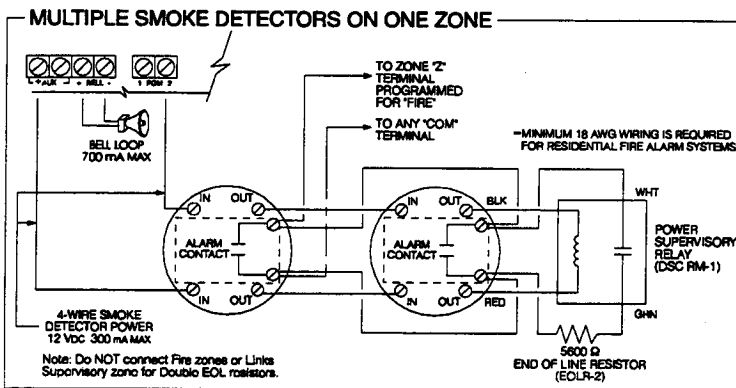
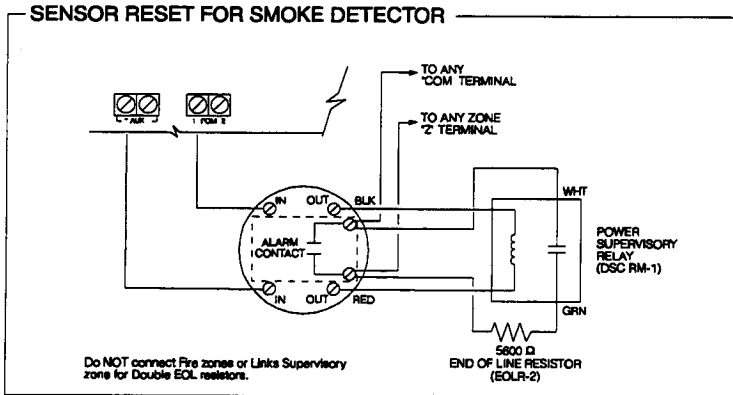

For a complete description of how fire zones operate, see Section 5.1 "Zone Definitions".

2.9.5 Fire Zone Wiring - 2 wire Smoke Detectors

If PGM2 has been programmed for 2 Wire Smoke Detector connection (See Section 5.10 "PGM Output"), the detectors must be wired according to the following diagram:

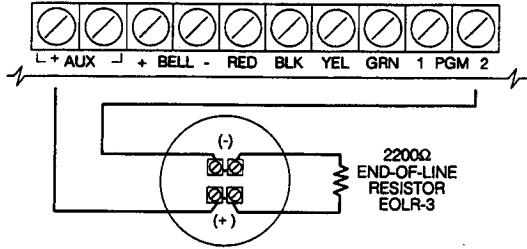

For a complete description of how fire zones operate, see Section 5.1 "Zone Definitions".

! If PGM2 is programmed for 2 wire smoke support, Jumper J1 on the main board must be removed.

2.9.6 Keyswitch Zone Wiring

Zones may be programmed to be used as keyswitch arming zones and must be wired according to the following diagrams:

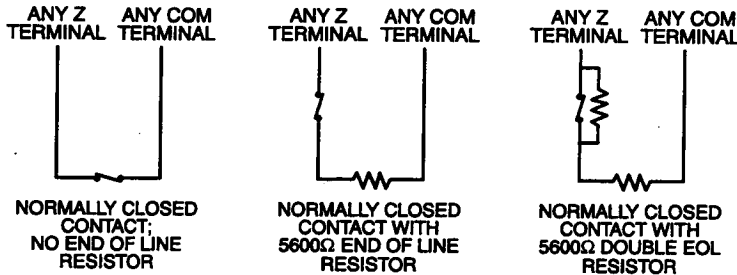

For a complete description of how keyswitch zones operate, see Section 5.1 "Zone Definitions".

2.9.7 LINKS Supervisory (Shall not be used on UL certificated systems)

If the LINKS 1000 cellular communicator is being used a zone may be configured for LINKS Supervisory (See Section 5.1 "Zone Definitions"). If the LINKS 1000 experiences a trouble it will violate the zone, causing the panel to report the event to central station.

The zone programmed as LINKS Supervisory ALWAYS requires a single EOL resistor (5.6K) and must be wired according to the following diagram:

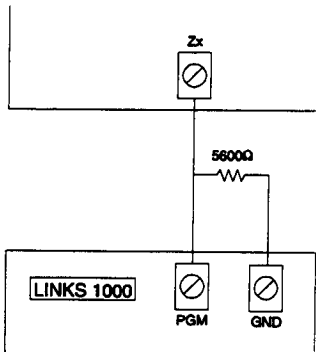

2.9.8 LINKS Answer (Shall not be used on UL certificated systems)

If the LINKS 1000 cellular communicator is being used a zone may be configured for LINKS Answer to allow downloading to be performed in the event of phone line failure.

When the LINKS receives a phone call it will activate the RING terminal on the LINKS circuit board. This terminal can be used to violate a zone programmed as LINKS Answer (See Section 5.1 "Zone Definitions"), causing the panel to seize the phone line and begin communication with the downloading computer.

The zone programmed as LINKS Answer ALWAYS requires a single EOL resistor (5.6K) and must be wired according to the following diagram:

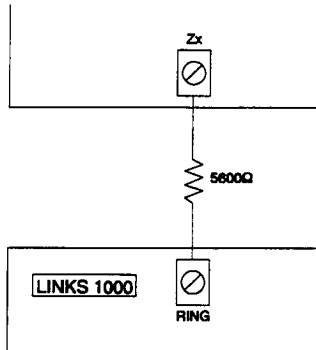

Keypad Commands

S E C T I O N 3

All keypads provide complete information and control of the alarm panel. The panel can be completely programmed via any keypad on the system. LED keypads provide function indicator lights and individual zone indicator lights for the alarm circuits. The LCD keypad provides function indicator lights and word descriptions for zone status.

The following sections describe how to arm, disarm and perform other keypad functions.

3.1 Access Codes

The panel has a total of 37 Access Codes available.

- Access Codes [01] to [32] .. User Codes 1 to 32
- Access Code [33] Duress Code
- Access Code [34] Duress Code
- Access Code [40] System Master Code
- Access Code [41] Master Code
- Access Code [42] Master Code

System Master Code

The **System Master Code Not Changeable** option can be use to lock in the code. This will prevent the user from being able to change the System Master Code. If they attempt to change the code the keypad will sound a long error beep. The System Master Code can be used to arm or disarm the system and perform any keypad function.

If the code is lost it can be reprogrammed through Installer Programming.

-
- System Master Code Not Changeable Section [015], Option [6]
- System Master Code Section [007]
-

Master Codes

By default the Master Codes are not programmed. They must be programmed by the System Master Code. Once programmed, a Master Code can perform the same basic system functions as the System Master Code. In addition, it can be used to program the 32 User Codes and 2 Duress Codes on the system.

Duress Codes

By default Duress Codes are not programmed. They must be programmed by the System Master Code or Master Code. Once programmed if the Duress Code is used, the panel will activate a silent Duress alarm (See Section 5.7 "Communicator - Reporting Codes").

User Codes

By default the 32 User Codes are not programmed. They must be programmed by the System Master Code or Master Code. Once programmed the User Code can be used to arm or disarm the system. In addition, each User Code can be enabled or disabled for bypass ability (See Section 3.4 "[*] Commands, [*] [1] Zone Bypass").

3.2 Arming

The system cannot be armed unless the 'Ready' light is on. If the 'Ready' light is not on make sure all protected doors and windows are secure and stop movement in areas covered by motion detectors.

If the 'Ready' light is on, press the 'Stay' or 'Away' key for 2 seconds.

3.2.1 Stay Arming

The system will be armed with all interior Stay/Away type zones **Bypassed** so that users can remain in the premises while armed. The perimeter zones will be armed.

3.2.2 Away Arming

The system will be armed with all interior Stay/Away type zones **Active**. If motion is detected on the Stay/Away type zones, the alarm sequence will begin.

3.3 Disarming

To disarm the panel enter the premises through the designated entry/exit door. The keypad will emit a steady beep to warn that you must disarm the system. During the last 10 seconds of entry delay the panel will pulse the keypad beeper on and off rapidly to warn the entry delay is about to expire. Enter a valid Access Code at the keypad. If an error is made press the [#] key and enter the code again. When a correct code is entered the keypad will turn off the 'Armed' light and stop the keypad buzzer. If an alarm occurred while the panel was armed the 'Memory' light and the zones which caused the alarm will be flashing. Press the [#] key to return the keypad to the Ready state.

3.4 [*] Commands

[*]+[1] Zone Bypass/Reactivate Stay/Away Zones

The [*] [1] keypad command can be used to bypass individual zones. It can be used if the user wants to have access to an area while the system is armed or to bypass a defective zone (bad contact, damaged wiring) until service can be provided.

The system can be armed with a bypassed zone. A bypassed zone will not cause an alarm.

If **Code Required for Bypass (required for UL Listed systems)** is enabled an access code will be required to enter the Bypass mode. Only user codes with the Bypass attribute enabled will be able to bypass zones (See Section 3.4 "[*] Commands, [*] [5]").

! Zones can only be bypassed when the system is disarmed.

To bypass a zone:

1. Enter [*] [1] (access code if required).
2. The keypad will flash the 'Bypass' light and turn on the zone lights for any zones already bypassed.
3. Enter the 2 digit zone number to bypass the zone.
4. The keypad will turn on the zone light.
5. Press [#].

All zones that were lit when the [#] key was pressed are now bypassed. The 'Bypass' light will be on steady to indicate zones are bypassed.

To un-bypass a zone:

1. Enter [*] [1] (access code if required).
2. The keypad will flash the 'Bypass' light and turn on the zone lights for any zones already bypassed.
3. Enter the 2 digit zone number to un-bypass the zone.
4. The keypad will turn off the zone light.
5. Press [#].

All zones that were lit when the [#] key was pressed are now bypassed. If no zones were lit, the 'Bypass' light will be off and no zones will be bypassed.

! When the system is disarmed all manually bypassed zones will be un-bypassed.

Reactivate Interior

If the system is armed in the Stay mode (See Section 3.2 "Arming/Disarming"), the [*] [1] command can be used to reactivate the Stay/Away zones.

.....
Code required for bypass - section [015], option [5]
.....

[*]+[2] Trouble Display

The panel constantly monitors itself for several different trouble conditions. If a trouble condition is present the 'Trouble' light will be on steady and the keypad will beep twice every 10 seconds.



The trouble beep can be silenced by pressing any key on any keypad.

To view trouble conditions:

1. Press [*] [2].
2. The keypad will flash the 'Trouble' light and light zones to indicate which trouble conditions are present.

A description of the various troubles are as follows:

Trouble [1] - Service Required

This light will be on if any of the following trouble conditions are detected by the control panel; Low Battery, Bell Circuit Trouble, General System Trouble, General System Tamper, General System Supervisory, WSS5204 Low Battery and WSS5204 AC Failure.

If a 'Service Required' trouble is present press [1] to determine the specific trouble present. The following is a list of the specific 'Service Required' trouble conditions:

- Light [1] - Low Battery
The main panel backup battery is low. The trouble will be generated if the battery drops below 11.5 volts under load and will restore when the battery charges over 12.5 volts.
- Light [2] - Bell Circuit Trouble
The panel will indicate this trouble if the Bell fuse is blown or the panel senses an open condition on the bell circuit (*See Section 5.12 "Siren Supervision"*).
- Light [3] - General System Trouble
This trouble will be present if the WSS5204 Power Supply module has an AUX failure, WSS5204 Output #1 Trouble, or a printer connected to the WSS5400 Printer module has a fault (off-line).
- Light [4] - General System Tamper
This trouble will be indicated if a Tamper Zone violation on any module is detected.
- Light [5] - General System Supervisory
This trouble will be indicated if the panel loses communication with any module connected to the KEYBUS (*See Section 2.7 "Enable Supervision"*). The event buffer will log a detailed description of the event.
A KEYBUS fault will also cause this trouble to be displayed. A KEYBUS fault will occur if one of the data lines (yellow or green wire) is shorted to ground.
- Light [6] - Not Used
- Light [7] - WSS5204 Low Battery
The WSS5204 module has a low backup battery.
- Light [8] - WSS5204 AC Failure
The WSS5204 module has lost AC power.

Trouble [2] - AC Failure

This trouble indicates that AC power is no longer being supplied to the control unit. If it is required to communicate this to a monitoring station, program reporting codes in sections [349] and [350]. To inhibit reporting of short duration power outages, a delay can be programmed in section [370].

Trouble [3] - Telephone Line Trouble

The telephone connection to the control unit is continuously monitored. If there is a problem with the telephone connection, a trouble will be indicated after the delay programmed in section [370]. If the system has a LINKS 1000, this trouble can be reported to a monitoring station by programming reporting codes in sections [349] and [350].

Trouble [4] - Failure to Communicate (FTC)

If the communicator fails in an attempt to communicate with any of the programmed telephone numbers, this trouble will be generated. If a later attempt is successful, the FTC reporting code(s) programmed in section [351] will be transmitted along with any other unreported events that occurred while the panel was not able to communicate.

Trouble [5] - Zone Fault (including Fire Zone)

This trouble will be indicated if any zone on the system is in a trouble condition, i.e. it could not provide an alarm to the panel if required to do so. When a trouble condition occurs, the keypad(s) will start to beep. Press [5], while in Trouble mode, to view which zones have a trouble condition. If 2-wire smoke detectors are being used, a trouble on that zone will be indicated by the "Fire" LED.

Trouble [6] - Zone Tamper

This trouble is only generated by zones configured for Double End-of-Line Resistor Supervision. This trouble is generated when a tamper condition is present. When a tamper condition occurs, the keypad(s) will start to beep.

Press [6], while in Trouble mode, to view which zones have a tamper condition.

Trouble [7] - Zone Low Battery

This trouble is generated when an RF device reports a low battery condition to the control unit. Press [7] while in Trouble mode to view which RF zones have a low battery.

Trouble [8] - Loss of System Time

This trouble occurs when the control unit is powered up and the internal clock has not been set. Setting the time with User Function [*][6][Master Code][1] will clear this trouble.

[*]+[3] Alarm Memory

The 'Memory' light will be on if any alarm occurred during the last armed period or if an alarm occurred while the panel was disarmed (24 hour zones).

To view alarm memory:

1. Press [*] [3].
 2. The keypad will flash the Memory light and light up zone lights to indicate alarm or tamper conditions that occurred during or since the last armed period.
- When the panel is armed the 'Memory' light will go out.

[*]+[4] Door Chime On/Off

If enabled the keypad will beep 5 times rapidly when a zone is tripped and restored. The panel will only do this for zones with the Door Chime attribute enabled and if the door chime feature is enabled (See Section 5.2 "Zone Attributes").

To turn Door Chime on/off:

1. Press [*] [4].
2. If the keypad beeps 3 times rapidly the Door Chime feature is enabled, one long beep means it is disabled.

[*]+[5] Programming Access Codes

There are 37 Access Codes available. They are as follows:

- Access Code [01] to [32] . User Codes 1 to 32
- Access Code [33] Duress Code
- Access Code [34] Duress Code
- Access Code [40] Master Code
- Access Code [41] Master Code
- Access Code [42] Master Code

All Access Codes have the ability to arm/disarm the system and activate the PGM Outputs using the [*][7][Access Code][1] and [*][7][2] commands (See Section 3.4 "[*] Commands, [*][7]").

Additional Access Code Attributes are also programmable. Attributes determine what abilities the code will have. The Attributes programmable are as follows:

- Operation enable
- Zone Bypass enable

User Codes - Access Codes [01] to [32]

Each User Code can be programmed to have the ability to bypass zones.



"Master" attributes cannot change. By default, each code has the attributes of the code used to program it.

Duress Codes - Access Codes [33] and [34]

When a Duress Code is used to perform any function the panel will report a Duress Reporting Code (See Section 5.7 "Communicator - Reporting Codes").

Master Codes - Access Codes [41] and [42]

Master Codes can program additional User Codes and the Duress Code.

System Master Code - Access Code [40]

By default the System Master Code is enabled to perform any keypad function. This code can be used to program all User Codes as well as the Master Codes and Duress Codes.

If the **Master Code Not Changeable** option is enabled the System Master Code can only be changed using Installer Programming.

How to program Access Codes:

Programming Access Codes is a two step process. First the Code must be programmed followed by the Code Attributes.

1. Enter [*] [5] [Master Code]. The keypad will flash the 'Program' light and turn on the zone light for any code already programmed.
2. Enter the 2 digit number for the code you want to program. The corresponding zone light will flash.
3. Enter a 4 digit code. The zone light will turn on steady.
4. Continue with step 2 until all codes are programmed.



***Do not press [*] or [#] when programming the 4 digit code.
When programming Duress Codes or Master Codes no zone light will flash.***

After all the Codes have been programmed press the [#] key to return to the Ready mode.

How to program Access Code Attributes:

"Master" attributes cannot change. By default, each code has the attributes of the code used to program it.

1. Enter [*][5][Master Code]. The keypad will flash the 'Program' light and turn on the zone light for any code already programmed.
2. Press [9] to enter the Attribute mode. The keypad will turn on the 'Ready' light and turn off the armed light.
3. Enter the 2 digit number for the code you want to program Attributes for. Zone lights [1] to [4] will be on or off. Refer to the following chart:
 - Zone Light 1 - ON - User Code enabled
 - Zone Light 2 - ON - For future use
 - Zone Light 3 - ON - enable manual bypass
4. Enter [1] to [3] to turn the zone lights ON or OFF.
5. Continue with steps 2 and 3 until all code attributes are programmed.

After all the codes and attributes have been programmed press the [#] key to exit Access Code Programming.

How to erase Access Code:

Select the code to be erased and press [*].

[*]+[6] User Functions

This keypad command can be used to program several different functions. The following are the items programmable:

- [1] - Time and Date
- [2] - For future use
- [3] - For future use
- [4] - System Test
- [5] - Enable DLS (Downloading)
- [6] - For future use
- [7] - For future use

To program User Functions:

1. Press [*] [6] [Master Code]. The keypad will flash the 'Program' light.

2. Press the number [1] to [5] for the item to be programmed.

- [1] - Time and Date

The time and date must be accurate for the Test Transmission function to work properly. In addition the event buffer time and date stamps all events.

- Enter the time, hour and minute, using military format [HH MM]. (00:00 to 23:59)
- Enter the date, month, day and year [MM DD YY].

! All entries must be 2 digits. January, for example, would be month [01].

- [2] - For future use
- [3] - For future use

! All entries must be 2 digits. Eight o'clock in the morning would be [08] hours and [00] minutes.

- [4] - System Test

When [4] is pressed the panel will perform the following:

- sound the alarm output for two seconds
- light all lights on keypads
- sound all keypad buzzers for two seconds
- test the main panel battery
- send a System Test Reporting code, if programmed (See Section 5.7 "Communicator - Reporting Codes").

- [5] - Enable DLS (Downloading)

When [5] is pressed the panel will turn on the downloading option for 6 hours. During this time the panel will answer incoming downloading calls (See Section 5.8 "Downloading").

- [6] - For future use
- [7] - For future use

! Additional Features are available using on the LCD keypad. These features do not have numbers assigned. Use the arrow keys (< >) to scroll through the [*] [6] menu and press the [*] key to select the following commands.

View Event Buffer

The 128 Event Buffer can be viewed through any LCD keypad (See Section 5.16.1 "Viewing the Event Buffer Through the LCD Keypad").

Brightness Control

When this option is selected the keypad will allow you to scroll through 10 different backlight level options. Use the arrow keys (<>) to scroll to the desired backlight level and press the [#] key to exit.

Contrast Control

When this option is selected the keypad will allow you to scroll through 10 different contrast level options. Use the arrow keys (<>) to scroll to the desired contrast level and press the [#] key to exit.

Keypad Buzzer Control

When this option is selected the keypad will allow you to scroll through 21 different keypad sounder tone options. Use the arrow keys (<>) to scroll to the desired keypad beeper level and press the [#] key to exit. This function can be achieved on LED keypads by holding the [*] key.

[*]+[7] Utility Output Functions

Two Utility Output Functions can be performed at a keypad. They are Door Strike and Smoke Detector Reset.

To activate Door Strike:

Press [*] [7] [1][Access Code].

The panel will activate all PGM Outputs for 5 seconds programmed as Utility Output (see Section 5.10 "PGM Outputs").

To activate Smoke Detector Reset:

Press [*] [7] [2].

The panel will activate all PGM Outputs for 5 seconds programmed as Sensor Reset. This command will also reset two wire smoke detectors connected to PGM2 programmed as Two Wire Smoke Reset (see Section 5.10 "PGM Outputs").

[*]+[8] Installer Programming

Enter [*][8] followed by the Installer Code to enter Installer Programming (see Section 4.0 "How to Program").

[*]+[9] Arming Without Entry Delay

When the system is armed with the [*][9] command the panel will remove the entry delay from the system. After the exit delay, Delay 1 and Delay 2 type zones will be instant and Stay/Away zones will remain bypassed (see Section 5.1 "Zone Definitions").

A valid access code must be entered after pressing [*] [9].

[*]+[0] Quick Exit

Quick Exit will allow someone to leave an armed premise through a Delay type zone without having to disarm and rearm the system.

When [*][0] is entered, if the Quick Exit Enabled option is enabled, the panel will provide a two minute window to exit. During this time the panel will ignore any ONE activation of a Delay type zone. When the Delay zone is secured the panel will end the two minute time period.

If a second Delay zone is tripped, or if the zone is not restored after two minutes, the panel will start entry delay.

! If Quick Exit is used on a system, Keypad Blanking and Access Code Required to Remove Blanking should be enabled.

- Code Required for Bypass Section [015], Option [5]
- Master Code Not Changeable option Section [015], Option [6]
- Quick Exit Enable Section [015], Option [3]

The Quick Exit feature is designed to allow the end user to violate a delay zone without having to disarm and rearm the system. The user can use the feature to let the dog out or get the morning paper by entering a simple keypad command.

Another example of this would be the person who leaves for work at 6:00 am while their spouse or children are sleeping. They can enter the Quick Exit command and leave without affecting the status of the system. The interior zones will remain bypassed while the perimeter remains armed.

3.5 Function Keys

There are 5 function keys on the WSS5010 keypads labeled Stay, Away, Chime, Reset and Exit. The operation of these keys is described below. The function is activated by pressing and holding the key for 2 seconds.

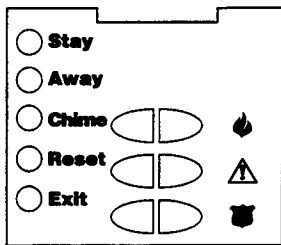

“Stay” - Stay Arm

Arms the system. All Stay/Away type zones will be automatically bypassed. Delay type zones will provide entry and exit delay.

“Away” - Away Arm

Arms the system. All Stay/Away type zones will be active at the end of the exit delay. Delay type zones will provide entry and exit delay.

“Chime” - Door Chime On/Off

Pressing the key will toggle the Door Chime feature ON or OFF. One solid beep means the feature has been disabled, three short beeps means it has been enabled.

“Reset” - Reset Smoke Detectors

Pressing this key will cause the panel to activate for 5 seconds any output programmed as Sensor Reset. In addition two wire smoke detectors connected to PGM2 will also be reset (See Section 3.4 “[*] Commands, [*][7][2]”).

“Exit” - Activate Quick Exit

Pressing this key will cause the panel to activate the Quick Exit feature (See Section 3.4 “[*] Commands, [*][0]”).

How to Program

S E C T I O N 4

The following section of the manual describes how to enter Installer Programming and how to program the various sections.

! *It is extremely important that you read the following section of the manual to completely understand how to program the panel.*

4.1 How to Enter Installer Programming

Installer Programming is used to program all communicator and panel options. The **Installer Code** is [5010] at default but may be changed to prevent unauthorized access to programming.

LED Keypad

Step 1 From any keypad enter [*][8][Installer Code].

- The 'Program' light will flash to indicate you are in programming
- The 'Armed' light will turn on to indicate the panel is waiting for the 3 digit Section number to program

Step 2 Enter the 3 digit Section number you want to program.

- The Armed light will turn off
- The Ready light will turn on to indicate the panel is ready for the information for the selected Section

! *If the 3 digit Section numbered entered is not valid or the module that pertains to the Section is not present the keypad will sound a 2 second beep or error tone.*

LCD Keypad

Step 1 From any keypad enter [*][8][Installer Code].

The Keypad will display 'Enter Section' followed by three dashes.

Step 2 Enter the 3 digit Section number you want to program.

The keypad will now display information for the section entered.

.....
Installer Code Section [006]
.....

4.2 Programming Decimal Data

When the Ready light is ON the panel is waiting for the information to be programmed for the selected Section. Enter the information written in the boxes for the Section found in the Programming Worksheets.

If a digit is entered for each program box in a Section the panel will automatically exit from the Section. It will turn OFF the Ready light and turn the Armed light back ON.

You can also press the [#] key to exit a Section before entering data for every box. This is handy if you only need to change the first few program boxes. All other locations in the Section will remain unchanged. If the [#] key is pressed the panel will turn off the Ready light, turn on the Armed light and exit you from the Section.

4.3 Programming HEX Data

On occasion, hexadecimal (HEX) digits may be required. To program a HEX digit press the [*] key. The panel will enter HEX programming and Ready light will begin to flash.

The following table indicates which number should be pressed to enter the corresponding HEX digit:

1 = A 2 = B 3 = C 4 = D 5 = E 6 = F

After the correct HEX digit is entered the 'Ready' light will continue to flash. If another HEX digit is required press the corresponding number. If a decimal digit is required press the [*] key again. The 'Ready' light will turn on solid and the panel will return to regular decimal programming.

! *It is important to watch the 'Ready' light. If the light is flashing any number you enter will be programmed as the HEX equivalent.*

Example: To enter 'C1' for a closing by user 1, you would enter [*] [3] [*], [1]

[*] to enter Hexadecimal mode ('Ready' light flashes)

[3] to enter C

[*] to return to decimal mode ('Ready' light is solid)

[1] to enter digit 1

If you enter information into a section and make a mistake, press the [#] key to exit the section. Select that section again and re-enter the information correctly.

4.4 Programming Toggle Option Sections

Some Sections contain several toggle options. The panel will use zone lights 1 through 8 to indicate if the different options are enabled or disabled. Refer to the Programming Worksheets to determine what each option represents and whether the light should be ON or OFF for your application.

Press the number corresponding to the option to toggle the light ON or OFF.

Once all the toggle options have been selected correctly press the [#] key to exit the Section and save the changes. The panel will turn off the Ready light and turn on the Armed light.

4.5 Viewing Programming

LED Keypads

Any program Section can be viewed through the keypad. When a Section is entered the keypad will immediately display the first digit of information programmed in that Section.

The keypad displays the information using a binary format where:

Zone Light 1 = 1

Zone Light 2 = 2

Zone Light 3 = 4

Zone Light 4 = 8

Add up the values for the zone lights to determine the number displayed (for example, no zone lights = 0, all 4 zone lights = 15 HEX 'F').

Press any of the Emergency Keys (Fire, Auxiliary or Panic) to advance to the next digit. When all the digits in a Section have been viewed the panel will exit the Section, turn off the Ready Light, turn on the Armed light and wait for the next three digit Section number to be entered. If the [#] key is pressed the panel will also exit the Section.

LCD Keypad

Any program Section can be viewed through the keypad. When a Section is entered the keypad will immediately display all the information programmed in that Section.

Use the arrow keys (<>) to scroll through the data being displayed.

Scroll past the end of the data displayed or press the [#] key to exit the Section.

Program Descriptions

S E C T I O N 5

The following section explains all the features programmable including how the feature operates, options that pertain to the feature and a summary of program locations that require programming.

5.1 Zone Definitions

These sections will allow you to select how each of the 32 zones will operate. Each zone requires a 2 digit entry.



In addition to selecting how each zone will operate, attributes may be programmed by zone including:

- ***alarm output audible or silent***
- ***alarm output steady or pulsed***
- ***zone activates/does not activate chime***
- ***zone can be/cannot be manually bypassed***
- ***zone does/does not have swinger shutdown***
- ***zone does/does not have transmission delay***

All zones, with the exception of 24 Hour and Fire have exit delay. When the system is armed the zones may be violated during the exit delay without causing an alarm.

See Section 5.9 "Zone Assignments".

[00] Null Zone

The zone will not operate in any way. Zones that are not used should be programmed as Null zones.

[01] Delay 1 Zone

If this zone is violated when the panel is armed it will provide entry delay. The keypad buzzer will sound to warn the user that the system must be disarmed. If the panel is not disarmed before the entry delay expires an alarm will be generated. Typically this type of zone will be used for the front door, back door or any other entry/exit point. Refer to Section [005] to program the Delay 1 zone entry delay time.

[02] Delay 2 Zone

This zone type operates the same as the Delay 1 zone option but can provide a different entry delay. Typically this zone will be used for a garage door. Refer to Section [005] to program the Delay 2 zone entry delay time.

[03] Instant Zone

If this zone type is violated when the panel is armed it will cause an instant alarm. Typically this zone is used for windows, patio doors or other perimeter type zones.

[04] Interior Zone

If this type of zone is violated when the panel is armed it will provide entry if a delay type zone was violated first. Otherwise it will cause an instant alarm. Typically this zone is used for interior protection devices, such as motion detectors.

[05] Interior Stay/Away Zone

This zone type works the same as the Interior zone type with one exception. The zone will be automatically bypassed under the following conditions:

- the panel is armed in the Stay Mode (*See Section 3.5 "Function Keys"*)
- the panel is armed without entry delay (*See Section 3.4 "[*] Commands, [*][9]"*)
- the panel is armed and during the exit delay a Delay type zone is NOT tripped

The automatic bypass avoids having the user manually bypass interior type zones when arming at home. If automatically bypassed, the user can reactivate the zones by entering the [*][1] command (*See Section 3.4 "[*] Commands, [*][1] Zone Bypass"*). Typically this zone is used for interior protection devices, such as motion detectors. Stay/Away zones should not be programmed as global zones.

[06] Delay Stay/Away Zone

This zone type will operate the same as the Interior Stay/Away zone type except that it will always provide entry delay. Typically this zone is used for interior protection devices, such as motion detectors and will help prevent false alarms since it will always provide the user the entry delay time to turn off the panel. Stay/Away zones should not be programmed as global zones.

[07] Delayed 24 Hour Fire Zone

If this zone is violated the alarm output will immediately activate but the communicator will be delayed for 30 seconds. If during the 30 second delay the user presses any key on any keypad the alarm output and communicator will be delayed an additional 90 seconds, providing the user time to correct the problem. If after the 90 second delay the zone is still violated the process will begin again; the alarm output will be activated but the communication will be delayed 30 seconds...

If the user does not press a key, after 30 seconds the alarm output will latch and the panel will communicate. The alarm will sound for the Bell Cutoff time programmed in *Section [005], "System Times"* or can be programmed to sound until a valid code is entered, *Section [014], "Second System Option Code, option [8]"*.



If a second Fire type zone is violated or the Fire keys are pressed during the delay time the panel will latch the alarm output and communicate immediately.

If a Fire zone is violated it will be displayed on all keypads and can be delayed at any keypad. Typically this zone is used for latching smoke detectors.

[08] Standard 24 Hour Fire Zone

When violated the panel will immediately latch the alarm output and communicate to central station. The alarm will sound for the Bell Cutoff time programmed in *Section [005], "System Times"* or can be programmed to sound until a valid code is entered, *Section [014], "Second System Option Code, option [8]"*.

If a Fire zone is violated it will be displayed on all keypads. Typically this zone is used for pull stations.

[09] 24 Hour Supervisory Zone (with LINKS)

If this zone is violated, whether armed or disarmed, the panel will report to the central station, and log the zone fault.

[10] 24 Hour Supervisory Buzzer Zone

Whether armed or disarmed, when this zone type is violated the panel will immediately latch the keypad buzzer until a valid user code is entered and will communicate immediately to central station.

[11] 24 Hour Burglary Zone

If this zone is violated, whether armed or disarmed, the panel will immediately latch the alarm output and communicate to the central station. The alarm will sound for the Bell Cutoff time programmed in *Section [005] "System Times"* or until a valid user code is entered.

[12] 24 Hour Holdup Zone

This zone operates similar to the 24 Hour Burglary except for System Event output type and SIA identifier.

[13] 24 Hour Gas Zone

This zone operates similar to the 24 Hour Burglary except for System Event output type and SIA identifier.

[14] 24 Hour Heat Zone

This zone operates similar to the 24 Hour Burglary except for System Event output type and SIA identifier.

[15] Not used

[16] 24 Hour Panic Zone

This zone operates similar to the 24 Hour Burglary except for System Event output type and SIA identifier.

[17] 24 Hour Emergency Zone (Non-medical emergency only)

This zone operates similar to the 24 Hour Burglary except for System Event output type and SIA identifier.

[18] 24 Hour Sprinkler Zone

This zone operates similar to the 24 Hour Burglary except for System Event output type and SIA identifier.

[19] 24 Hour Water Flow Zone

This zone operates similar to the 24 Hour Burglary except for System Event output type and SIA identifier.

- [20] **24 Hour Freezer Zone**
This zone operates similar to the 24 Hour Burglary except for System Event output type and SIA identifier.
- [21] **24 Hour Latching Tamper**
If this zone is violated the installer must enter Installer Programming before the panel to be armed.
- [22] **Momentary Keyswitch Arm Zone**
Momentary violation of this zone will alternatively arm/disarm the system. This zone type should not be programmed as global.
- [23] **Maintained Keyswitch Arm Zone**
When this zone is violated the system will disarm. When the zone is secured the system will arm. This zone type should not be programmed as global.
- [24] **LINKS Answer Zone**
If the LINKS 1000 cellular communicator is being used it is possible to perform downloading through the unit if the phone line is disconnected. If this is required connect the RING terminal of the LINKS 1000 to this zone. Refer to the LINKS 1000 Installation sheet for more information.
- [87] **Not used**
- [88] **Not used**

5.2 Zone Attributes

Each zone will operate according to the Zone Definition selected for it (*See Section 5.1 "Zone Definitions"*).

Additional zone attributes can be programmed to customize the operation of a zone for a specific application. The following attributes are programmable by zone:



Attributes for Fire Zones should not be changed from default.

Audible/Silent

Determines whether the zone will activate the alarm output or will be silent.

Pulsed/Steady

Determines if the alarm output will be steady or pulse on for 1 second and off for one second.

Activate Chime

Determines if the zone will activate the chime feature (*See Section 3.4 "[*] Commands, [*] [4] Door Chime ON/OFF"*).

Bypass Enable

Determines if the zone can be manually bypassed (*See Section 3.4 "[*] Commands, [*] [1] - Zone Bypass"*).

Swinger Shutdown Enable (Shall not be enabled on UL Listed systems)

Determines if the panel will shut down the communicator for the zone after the swinger limit is reached (*See Section 5.17 "Swinger Shutdown"*).

Transmission (TX) Delay Enable

Determines if the panel will delay communicating the alarm reporting code to the central station (*See Section 5.18 "Transmission Delay"*).

.....

Zones 1 to 32 Attributes Section [101] - [132]

Audible/Silent Alarm Section [101] - [132], Option [1]

Pulsed/Steady Alarm Section [101] - [132], Option [2]

Activate Chime Section [101] - [132], Option [3]

Bypass Enable Section [101] - [132], Option [4]

Swinger Shutdown Enable Section [101] - [132], Option [6]

Transmission Delay Enable Section [101] - [132], Option [7]

.....

5.3 Communicator - Dialing

If the **Communicator Disable** option is selected the panel will not attempt to call central station. If enabled the panel will attempt to call central station when an event occurs that has a valid reporting code programmed (See Section 5.7 "Communicator - Reporting Code").

Communicator Call Direction Options are used to select which phone number the panel will dial when an event occurs.

If **DTMF Dialing** is enabled the panel will dial using DTMF (touch tone). If **Switch to Pulse Dial** is enabled the panel will switch to pulse dialing on the 5th attempt to call the central station. If disabled the panel will always dial DTMF.

If **DTMF Dialing** is disabled the panel will always pulse dial.

The **Post Dial Wait for Handshake** determines the amount of time the panel will wait for a valid handshake from the receiver. If the panel does not hear the handshake it will consider the call a failed attempt, hang up and try again.

The **Maximum Dialing Attempts** determines the maximum number of attempts the panel will make to send a signal to central station before indicating a Failure to Communicate (FTC) trouble condition. The 3rd Phone Number can be used to back up the 1st in this situation (See Section 5.4 "Communicator - Phone Numbers").

.....

Pulse Dialing Section [380], Option [3]

Switch to Pulse Dial Section [380], Option [4]

Post Dial Wait for Handshake Section [161]

Maximum Dialing Attempts Section [160]

Communicator Disable Section [380], Option [1]

Communicator Call Direction Options Section [361] to [368]

.....

5.4 Communicator - Phone Numbers

The panel can call 3 different phone numbers for communication to central station. The **1st Phone Number** is the primary number, the **2nd Phone Number** is the secondary number and the **3rd Phone Number** will back up the 1st phone number if enabled.

! *The 3rd Phone Number will NOT back up the 2nd Phone Number.*

If **Alternate Dial** is enabled the panel will alternate between the 1st and 3rd phone numbers when attempting to call the central station. If disabled the panel will only attempt to call the 3rd phone number after failing to communicate on the 1st phone number.

! *For Alternate Dial to work properly the 3rd Phone Number must be enabled.*

Phone numbers can be up to 32 digits which will allow you to add special digits if required. To program the phone number enter numbers 0 through 9 as required. The following is a list of HEX digits which can also be programmed and the function they perform:

- HEX (B) - simulates the [*] key on a touch tone phone
- HEX (C) - simulates the [#] key on a touch tone phone
- HEX (D) - forces the panel to search for dial tone
- HEX (E) - forces the panel to pause for 2 seconds
- HEX (F) - end of phone number marker

-
- 1st Phone Number Section [301]
- 2nd Phone Number Section [302]
- 3rd Phone Number Section [303]
- 3rd Phone Number Enable Section [380], Option [5]
- Alternate Dial Section [380], Option [6]
-

5.5 Communicator - System Identifier Code

The System Identifier Code is used by central station to determine which panel is calling.

-
- System Identifier Code Section [310]
-

Note: UL has only verified compatibility with the Sur-Gard SG-MLR2-DG.

5.6 Communicator - Reporting Formats

Each central station phone number of the panel can be programmed to report using either the SIA or Pager format.

5.6.1 SIA

SIA is a specialized format that will communicate information quickly using tones rather than pulses. The SIA format will automatically generate the type of signal being transmitted, such as Burglary, Fire, Panic etc. The two digit reporting code is used to identify the zone or user code number.

! If the SIA format is selected the panel can be programmed to automatically generate all zone and user codes numbers eliminating the need to program these items.

If the SIA Sends Automatic Reporting Codes option is enabled the panel will operate as follows:

1. If the reporting code for an event is programmed as [00] the panel will not attempt to call the central station.
2. If the reporting code for an event is programmed as anything from [01] to [FF] the panel will AUTOMATICALLY generate the zone or user code number.

The Communicator Call Direction Options can be used to disable reporting of events such as Openings/Closings. Also, if all the Opening/Closing reporting codes were programmed as [00] the panel would not report.

If the SIA Sends Automatic Reporting Codes option is disabled the panel will operate as follows:

1. If the reporting code for an event is programmed as [00] or [FF] the panel will not attempt to call central station.
2. If the reporting code for an event is programmed as anything from [01] to [FE] the panel will send the programmed reporting code.

Refer to Appendix B for a list of SIA identifiers.

.....

Communicator Format Section [360]

SIA Sends Automatic Reporting Codes Section [381], Option [3]

Communicator Call Direction Options Section [361] to [368]

SIA Identifiers Appendix B

.....

The ability to program regular two digit reporting codes gives great flexibility. For example, the panel can automatically report SIA to the 1st phone number and use the 2nd phone number for the Pager format.

5.6.2 Pager Format

The **Communicator Format** option for either phone number can be programmed for Pager Format. If an event occurs and the **Communicator Call Direction** options direct the call to a phone number with the Pager Format selected the panel will attempt to page.

When calling a pager extra digits will be required to make it work properly.

The following is a list of Hex digits and what function they perform:

- Hex [B] - simulates the [*] key on a touch tone phone
- Hex [C] - simulates the [#] key on a touch tone phone
- Hex [D] - forces the panel to search for dial tone
- Hex [E] - two second pause
- Hex [F] - end of phone number marker

The panel will attempt to call the pager one time. After dialing the digits in the phone number the panel will send the account number and reporting code followed by the [#] key (Hex [C]).

The panel has no way of confirming if the pager was called successfully which means a failure to communicate trouble will never be generated.

! The Pager Format cannot be used with the LINKS 1000 cellular communicator.

.....

Communicator Format Options Section [360]

Communicator Call Direction Options Section [361] to [368]

.....

The pager format is perfect for the parent who works late and wants to know if their child arrived home safely. When the child disarms the system the parent is paged. Since opening/closing reporting is done by user the system can be programmed to only page when the child user code is used. The pager format can also be used for a keyholder in the event of an alarm. The panel will call central station then call the keyholders pager to also alert them that an alarm has occurred.

5.7 Communicator - Reporting Codes

The panel can be programmed to report events to a central station. The panel will send the reporting code programmed for the event.

Reporting codes can be one or digits and can use HEX digits (A through F). The following is a description of the different reporting codes that can be programmed and when the events will be reported to central station.

5.7.1 Zone Alarm

The panel will transmit the **Zone Alarm** Reporting Code for a zone when the zone goes into alarm. 24 hour type zones will go into alarm whether the panel is armed or disarmed and report to central station. All other type zones will only go into alarm if the panel is armed.

5.7.2 Zone Restoral

If the **Restoral on Bell Timeout** option is selected the panel will send the **Zone Restoral** Reporting Code for the zone if the alarm output times out AND the zone is secure. If the zone is not secured when the alarm output times out the panel will send the restoral immediately after the zone is secured.

If the **Restoral on Bell Timeout** option is not selected the panel will immediately send the **Zone Restoral** Reporting Code when the zone is secured, regardless if the alarm output is active or not.



24 Hour type zones will report the restoral immediately after the zone is secured.

5.7.3 Closings

The panel will transmit a **Closing** Reporting Code to indicate the system is armed. A different reporting code can be transmitted for each User Code, Master Code and System Master Code to identify who armed the system.

A **Partial Closing** Reporting Code will be transmitted if the system is armed with zones manually bypassed.

A **Special Closing** Reporting Code will be transmitted if the system is armed using any of the following methods:

- Arming via the DLS Software
- Arming via keyswitch
- 'Away' Function Key arming
- 'Stay' Function Key arming

A Closing by Duress Code Reporting Code will be transmitted in addition to the Duress reporting code if the system is armed using a Duress Code.

A Recent Closing Reporting Code will be transmitted if an alarm occurs within 2 minutes of the exit delay expiring.

Several false alarms are created by the user at time of exit. By sending a Recent Closing reporting code along with the alarm it can alert central station that the user probably exited incorrectly.

5.7.4 Openings

The panel will transmit an **Opening** Reporting Code to indicate the system has been disarmed. A different reporting code can be transmitted for each User Code, Master Code and System Master Code to identify who disarmed the system.

A **Special Opening** Reporting Code will be transmitted if the system is disarmed using any of the following methods:

- Disarming via the DLS Software
- Disarming via keyswitch

An **Opening After Alarm** Reporting Code will be transmitted in addition to the opening when the system is disarmed after an alarm has occurred.

An **Opening by Duress** Reporting Code will be transmitted in addition to the Duress reporting code if the system is disarmed using a Duress Code.

The Opening After Alarm reporting code can be used to help identify false alarms and prevent erroneous dispatch. If the central station receives an alarm followed by the Opening After Alarm reporting code they know someone with a valid User Code has disarmed the system. Most likely the alarm was caused by the user forgetting to disarm the system.

5.7.5 Tamper

If the panel is programmed for Double EOL zones (*See Section 2.9 "Zone Wiring"*) the panel will report a **Zone Tamper Alarm** Reporting Code if an open condition is present on a zone. A different reporting code can be programmed for each zone for identification.

A **General System Tamper** Reporting Code will be transmitted when the tamper zone on any module is violated.

5.7.6 Priority/Emergency

The panel will transmit a **Keypad Fire Alarm** Reporting Code when the Fire Keys on any keypad is pressed for two seconds.

The panel will transmit a **Keypad Auxiliary Alarm** Reporting Code when the Auxiliary Keys on any keypad is pressed for two seconds.

The panel will transmit a **Keypad Panic Alarm** Reporting Code when the Panic Keys on any keypad is pressed for two seconds.

The panel will transmit a **Duress** Reporting Code any time either Duress Code is entered at any keypad. If the panel is armed using the Duress Code the panel will also transmit a **Closing by Duress** Reporting Code or if the panel is disarmed it will also transmit an **Opening by Duress** Reporting Code.

If PGM2 is being used for two wire smoke detectors (*See Section 5.10 "PGM Outputs"*) the panel will send a **Two Wire Smoke Alarm** Reporting Code if a smoke detector goes into alarm.

5.7.7 Maintenance

The panel will transmit a **Battery Trouble Alarm** Reporting Code when the backup battery drops below 11.5 Vbc. The **Battery Trouble Restoral** Reporting Code will not be transmitted until the battery has been charged over 12.5 Vbc.

To prevent the panel from transmitting an **AC Failure Trouble Alarm** Reporting Code during short power outages the panel will not send the signal unless AC power is lost for the amount of minutes programmed for the AC Failure Communication Delay. The **AC Failure Trouble Restoral** Reporting Code will be transmitted as soon as AC power is restored.

A **Bell Circuit Trouble Alarm** Reporting Code will be transmitted immediately when an open condition is measured on the Bell Output of the main panel. The **Bell Circuit Trouble Restoral** Reporting Code will be transmitted as soon as the problem is corrected.

A **Fire Trouble Alarm** Reporting Code will be transmitted immediately when an open condition is measured on any Fire type zone (*See Section 5.1 "Zone Definitions"*). The **Fire Trouble Restoral** Reporting Code will be transmitted as soon as the problem is corrected.

The **Auxiliary Power Supply Trouble Alarm** Reporting Code will be transmitted if the AUX output is shorted. The AUX output of the control incorporates a fuseless design. When excessive current is drawn the panel will automatically shut off the output. The panel will constantly check the AUX output and when the excessive current draw is removed the panel will reset the output and transmit an **Auxiliary Power Supply Trouble Restoral** Reporting Code.

A **TLM Trouble** Reporting Code can only be transmitted if a LINKS 1000 Cellular Communicator is being used (*See Section 5.26 "LINKS 1000 Cellular Communicator"*). The panel will only transmit the signal after the time programmed for the TLM Trouble Delay. The **TLM Restoral** Reporting Code will be transmitted within 10 seconds of the problem being corrected.

A **General System Trouble** Reporting Code will be transmitted if the panel detects any of the following on the WSS5204 Power Supply/Output Module: AC Power Failure, Low Battery, AUX Output Trouble or Output #1 Supervisory trouble. The **General System Trouble Restoral** Reporting Code will be transmitted when all of the listed problems are corrected.

A **General System Supervisory Trouble** Reporting Code will be transmitted if any module goes missing from the KEYBUS. If the module is a zone expander the panel will also transmit the **Zone Expander Supervisory Alarm Trouble** Reporting Code. The panel will send a **General System Supervisory Restoral** Reporting Code when the problem is corrected as well as a **Zone Expander Supervisory Restoral** Reporting Code if the module is a zone expander.

5.7.8 Test Transmissions

The panel can be programmed to transmit a **Periodic Test Transmission** Reporting Code (See Section 5.13 "Test Transmissions"), a **System Test** Reporting Code (See Section 3.4 "[*] Commands, [*] [6]") or a **LINKS 1000 Test Transmission** Reporting Code (See Section 5.26 "LINKS 1000 Cellular Communicator").

5.7.9 Wireless Maintenance

The panel will transmit a **General Zone Low Battery Alarm** Reporting Code if a low battery condition is indicated by a detector. The transmission of the trouble will be delayed by the number of days programmed for **Zone Low Battery Transmission Delay**. The **General Zone Low Battery Restoral** Reporting Code will be transmitted when the problem is corrected. The specific zone that caused the trouble will be stored to the Event Buffer.

! The restoral will not be transmitted until all detectors indicate a good battery condition.

5.7.10 Miscellaneous

The panel will transmit the **Keypad Lockout** Reporting Code if the lockout is activated (See Section 5.22 "Keypad Lockout").

The **DLS Lead In** Reporting Code will only be transmitted if the **DLS Call Back** feature is being used (See Section 5.8 "Downloading"). Before the panel calls the computer back it will call central station and transmit the reporting code to indicate a download session is about to begin. After downloading is complete the panel will transmit a **DLS Trail Out** Reporting Code to indicate the download session is complete.

If the panel fails to transmit information to the central station it will display a failure to communicate trouble condition. The panel will transmit a **Phone Number 1 Failure to Communicate** Reporting Code or a **Phone Number 2 Failure to Communicate** Reporting Code the next time it calls the central station. The panel will transmit the old events, followed by the failure to communicate, followed by the new events. This will allow central station to determine which events are old or new.

If the Event Buffer is uploaded on a regular basis an **Event Buffer 75% Full** Reporting Code can be transmitted to warn the Buffer is almost full. This is also useful if the WSS5400 Printer Module is being used.

.....

Zone Alarm Reporting Code	Section [320] to [323]
Restoral on Bell Timeout	Section [380], Option [2]
Zone Restoral Reporting Code	Section [324] to [327]
Closing Reporting Code	Section [339] to [342]
Partial Closing Reporting Code	Section [343]
Special Closing Reporting Code	Section [343]
Closing by Duress Code Reporting Code	Section [343]
Recent Closing Reporting Code	Section [328]
Opening Reporting Code	Section [344] to [347]
Special Opening Reporting Code	Section [348]
Opening After Alarm Reporting Code	Section [328]
Opening by Duress Reporting Code	Section [348]
Zone Tamper Alarm Reporting Code	Section [330] to [333]
Zone Tamper Restoral Reporting Code	Section [334] to [337]
General System Tamper Reporting Code	Section [338]
General System Tamper Restoral Reporting Code	Section [338]
Keypad Fire Alarm Reporting Code	Section [329]
Keypad Fire Restoral Reporting Code	Section [329]
Keypad Auxiliary Alarm Reporting Code	Section [329]
Keypad Auxiliary Restoral Reporting Code	Section [329]

Keypad Panic Alarm Reporting Code Section [329]
Keypad Panic Restoral Reporting Code Section [329]
Duress Reporting Code Section [328]
Two Wire Smoke Alarm Reporting Code Section [329]
Two Wire Smoke Alarm Restoral Reporting Code Section [329]
Battery Trouble Alarm Reporting Code Section [349]
Battery Trouble Restoral Reporting Code Section [350]
AC Failure Trouble Alarm Reporting Code Section [349]
AC Failure Communication Delay Section [370]
AC Failure Trouble Restoral Reporting Code Section [350]
Bell Circuit Trouble Alarm Reporting Code Section [349]
Bell Circuit Trouble Restoral Reporting Code Section [350]
Fire Trouble Alarm Reporting Code Section [349]
Fire Trouble Restoral Reporting Code Section [350]
Auxiliary Power Supply Trouble Alarm Reporting Code Section [349]
Auxiliary Power Supply Trouble Restoral Reporting Code Section [350]
TLM Trouble Reporting Code Section [349]
TLM Trouble Delay Section [370]
TLM Restoral Reporting Code Section [350]
General System Trouble Reporting Code Section [349]
General System Trouble Restoral Reporting Code Section [350]
General System Supervisory Trouble Reporting Code Section [349]
General System Supervisory Restoral Reporting Code Section [350]
Zone Expander Supervisory Trouble Reporting Code Section [328]
Zone Expander Supervisory Restoral Reporting Code Section [328]
Periodic Test Transmission Reporting Code Section [352]
System Test Reporting Code Section [352]
LINKS 1000 Test Transmission Reporting Code Section [352]
General Zone Low Battery Alarm Reporting Code Section [353]
Zone Low Battery Transmission Delay Section [370]
General Zone Low Battery Restoral Reporting Code Section [353]
Keypad Lockout Reporting Code Section [338]
DLS Lead In Reporting Code Section [351]
DLS Trail Out Reporting Code Section [351]
Phone Number 1 Failure to Communicate Reporting Code Section [351]
Phone Number 2 Failure to Communicate Reporting Code Section [351]
Event Buffer 75% Full Reporting Code Section [351]
•••••

5.8 Downloading

Downloading allows programming of the entire control panel via a computer, modem and telephone line. All functions and features, changes and status, such as trouble conditions and open zones can be viewed or programmed by downloading.

! *When power is applied to the panel downloading will be enabled for 6 hours. This will allow you to perform downloading without having to do any keypad programming.*

If the **Downloading Answer** option is enabled (or during the first 6 hours after power up) the panel will answer incoming calls for downloading provided the following conditions occur:

1. The panel hears one or two rings then misses a ring.
2. At this point the panel will start a timer.
3. If the panel hears another ring before the **Answering Machine Double Call Timer** expires it will answer on the first ring of the second call.

The panel will immediately go on line and begin the download process unless the **Call Back** option is enabled. If enabled, the panel and computer will both hang up. The panel will then call the **Download Computer Telephone Number** and wait for the computer to answer. Once the computer answers downloading will begin.

If **User Enable DLS Window** is enabled the user can turn the downloading feature on for 6 hours through the [*][6] keypad command. After 6 hours the panel will not answer incoming calls unless Downloading Answer is enabled (See Section 3.4 "[*] Commands, [*][6] User Functions").

The **Download Access Code** and **Panel Identifier Code** are for security and proper identification. Both the panel and the computer file should have the same information programmed before attempting to download.

If the LINKS 1000 cellular communicator is being used it is possible to download through the LINKS if the phone line is disconnected. If Call Back is being used you may have to program the **LINKS 1000 Preamble** to have the panel call back the computer correctly.

! For more information refer to the Download Manual included with the computer software.

.....

Downloading Answer Section [401], Option [1]

User Enable DLS Window Section [401], Option [2]

Call Back Section [401], Option [3]

Answering Machine Double Call Timer Section [405]

Download Computer Telephone Number Section [402]

Download Access Code Section [403]

Panel Identifier Section [404]

LINKS 1000 Preamble (Downloading) Section [490]

.....

Downloading provides so many benefits it is impossible to list them all. Panels can be programmed easily, quickly and accurately at time of installation. Area code changes will no longer require hours or days of service calls. Changes required such as features and options, delay times or user codes can be changed in minutes rather than scheduling a service call.

Diagnostics can be viewed and the event buffer retrieved before sending out a service vehicle to accurately determine the problem in advance.

You will be able to reduce service calls and at the same time offer your customer quick response to any problem they may encounter.

5.9 Zone Assignments

All zones must be assigned to the system in Sections [202] to [205] before they will function. By default, only zones 1 to 8 are assigned (Sections [202]). To assign the zones, turn the corresponding light or option ON in the section.

.....

Zone Assignments Section [202] to [205]

.....

5.10 PGM Outputs

There are 3 different types of Programmable Outputs available. They are listed as follows:

- PGM1 and PGM2 on the main board
- 8 low current outputs available with the WSS5208 Output Module
- 4 high current outputs available with the WSS5204 Power Supply/Output Module

Programming any of the PGM Outputs is a two step process. First an option from the below list must be selected for the PGM Output. Second the PGM Attributes must be selected. The following is a list of the PGM Output Options and PGM Attributes.

5.10.1 PGM Output Options

[01] Burglary and Fire Bell Output

The PGM output will activate when the alarm output is active and will turn off when the alarm output is silenced. If the alarm output is pulsing the PGM output will pulse as well. This output does not follow the pre-alert for delayed fire zones.

[02] Utility Output

The PGM output will activate for 5 seconds when the [*][7][1][Access Code] command is entered (See Section 3.0 "Keypad Commands").

[03] Sensor Reset

This option is used to reset power for latching smoke detectors.



The output will normally be active, switched to ground.

The output will deactivate for 5 seconds when the [*][7][2] command is entered (See Section 3.0 "Keypad Commands"). The keypad buzzer will not sound for the 5 second period.

Refer to the Hook-Up diagram in this manual for wiring instructions.

[04] Two-Wire Smoke Reset (PGM2 Only!)

PGM2 may be used in conjunction with two-wire smoke detectors. The output will operate the same as option [03].



PGM Output Attributes for PGM2 when used for two wire smoke detector reset must remain at default, Attribute 1, 2 and 3 ON.

Do not program any PGM output other than PGM2 for two-wire smoke detector support.

Refer to the Hook-Up diagram in this manual for wiring instructions (See Section 2.9.5 "Fire Zone Wiring - 2-Wire Smoke Detectors").

[05] System Armed Status

The PGM output will activate when the System is armed and deactivate when disarmed.

[06] Ready Output

The PGM output will activate when the System is ready to arm. The output will deactivate when the system is not secure or upon arming.

[07] Keypad Buzzer Follow

The PGM will activate when any of the following events occur and will remain active for as long as the keypad buzzer is active:

- Door Chime
- Audible Exit Delay
- Entry Delay
- 24 Hour Supervisory Buzzer Zone

[08] Courtesy Pulse

Upon arming the PGM output will activate for the duration of the exit delay plus two minutes. Upon entry the PGM output will activate for the duration of the entry delay plus 2 minutes. Only one courtesy pulse output may be programmed on a system.

[09] System Trouble

The PGM output will activate when any of the selected trouble conditions are present. It will deactivate when all the selected trouble conditions are cleared.

The normal PGM attributes, programmed in Sections [141] to [154] is replaced with the following list for any output selected as System Trouble:

- Light [1] Service Required (battery, bell, general trouble, general tamper, general supervisory)
- Light [2] AC Failure
- Light [3] Telephone Line Trouble
- Light [4] Failure to Communicate
- Light [5] Fire Trouble / Zone Fault
- Light [6] Zone Tamper
- Light [7] Zone Low Battery
- Light [8] Loss of Clock

[10] Latched System Event

The PGM output will activate when any of the selected events occur. It will deactivate when an access code is entered.

The normal PGM attributes, programmed in Sections [141] to [154] is replaced with the following list for any output selected as Latched System Event:

- Light [1] Burglary Delay, Instant, Interior, Stay/Away and 24 Hour Burglary Zones
- Light [2] Fire Fire Keys and Fire Zone
- Light [3] Panic Panic Keys and Panic Zone
- Light [4] Auxiliary Auxiliary Keys and Emergency Zones
- Light [5] Supervisory ... Supervisory, Freezer and Water Zones
- Light [6] Priority Gas, Heat, Sprinkler and 24 Hour Latching Zones
- Light [7] Holdup Holdup Zones and Duress Alarms
- Light [8] Not Used

[11] System Tamper

The PGM Output will activate when any Tamper condition is present and will deactivate when all Tamper conditions are cleared.

[12] TLM and Alarm

The PGM Output will activate when a telephone line fault condition is present AND an alarm occurs. The PGM Output will remain active until an access code is entered. The output will activate for both audible and silent alarms if a TLM trouble is present.

! This output will activate for all audible and silent alarms including Duress.

[13] KISSOFF

The PGM Output will activate for two seconds after the panel receives the kissoff from the central station.

[14] Ground Start (Shall not be used on UL Listed systems)

The PGM Output will activate for two seconds before the panel attempts to dial to obtain dial tone on Ground Start telephone equipment. Two 2-second pauses should be inserted at the beginning of the phone number when using this option.

[15] For future use

[16] LINKS 1000 Support (PGM1 Only)

The PGM output will be used as a data wire to communicate phone number information for the LINKS 1000 cellular unit.

-
- Main Board PGM Outputs Section [009]
- WSS5208 PGM Output Options Section [010]
- WSS5204 PGM Output Options Section [011]
-

5.10.2 PGM Output Attributes

Each Programmable Output also requires the PGM Attributes to be programmed before they will operate correctly. Attributes available are as follows:

- Option [1] - ON PGM enabled
 OFF PGM disenabled
- Option [2] - For future use
- Option [3] - ON Output Activates on Event
 OFF Output Deactivates on Event

! The Attribute Options for Option [09] System Trouble and [10] Latched System Event are different. Refer to these options for more information.

.....

PGM1 (Main Board) Output Attributes Section [141]

PGM2 (Main Board) Output Attributes Section [142]

WSS5208 PGM Output Attributes Section [143] to [150]

WSS5204 PGM Output Attributes Section [151] to [154]

.....

5.11 Telephone Line Monitor (TLM)

The panel will supervise the presence of the phone line and indicate a trouble condition if disconnected. If **TLM Enabled** is selected the panel will wait the **TLM Trouble Delay** time before indicating the trouble so that a momentary interruption of the phone line will not cause a trouble condition.

The **TLM Trouble Only** or **Audible When Armed** option will allow you to select if the panel will indicate a trouble condition at the keypad or indicate a trouble at the keypad when disarmed and activate the alarm output when armed.

When the trouble condition is restored the panel can send a **TLM Restoral Reporting Code**. Any events that occurred while the phone line was down will also be communicated.

If the LINKS 1000 cellular communicator is being used the panel can be programmed to report a **TLM Trouble Reporting Code**.

.....

TLM Enable/Disable Section [015], Option [7]

TLM Trouble Only or Audible When Armed ... Section [015], Option [8]

TLM Trouble Delay Section [370]

TLM Trouble Reporting Code Section [349]

TLM Restoral Reporting Code Section [350]

.....

The control panel has only two ways of communicating an alarm to the outside world; sound the siren and call central station. The WSS5010 supervises the telephone line connection and if it is cut or otherwise disconnected the panel will activate the local bell to discourage any intruder, in many cases before entry to the premises has been gained.

With the LINKS 1000 cellular unit the panel will be able to report this condition to central station.

5.12 Siren Supervision

The panel supervises the Bell output. If an open condition is detected or the fuse is blown the panel will immediately indicate a trouble condition and beep the keypad twice every ten seconds to alert the owner of the problem. The panel can send a **Bell Circuit Trouble** Reporting Code immediately. Once the problem is corrected the panel can send a **Bell Circuit Trouble Restoral** Reporting Code.

.....

Bell Circuit Trouble Reporting Code Section [349]

Bell Circuit Trouble Restoral Reporting Code Section [350]

.....

A very important part of the security system is the siren or bell output. The audible device will both frighten an intruder and draw attention to the break-in. If fire protection is being utilized the siren plays an extremely important role. Early detection and clear audible warnings in order to provide safe escape is the whole point of fire protection. Supervision of the bell circuit ensures the alarm will function in the event of a fire.

5.13 Test Transmission

To ensure the communication link with the central station is functioning properly the panel can be programmed to send a test transmission signal.

The panel can send a **Periodic Test Transmission Reporting Code** at the programmed **Test Transmission Time of Day**. The **Test Transmission Cycle** determines the number of days (001 to 255) between tests. If the test transmission is being programmed with a lesser value than the previous value, the system will wait the original period before the next test transmission is sent, and then begin reporting with the new interval.

If the LINKS 1000 cellular communicator is being used the panel can also send a cellular test. If the **LINKS 1000 Test Transmission Code** is programmed the panel will send a cellular test at the same time as the land line test transmission.

The end user can generate a communicator test. If the **System Test Reporting Code** is programmed the panel will send the signal when the System Test keypad command is entered (See Section 3.4 "[*] Commands, [*][6] User Functions").

.....

Periodic Test Transmission Reporting Code Section [352]

Test Transmission Time of Day Section [371]

Test Transmission Cycle Section [370]

LINKS 1000 Test Transmission Reporting Code Section [352]

System Test Reporting Code Section [352]

.....

Assurance the panel will communicate in the event of an alarm is important to both yourself and the end user. Having the panel send a test signal periodically will help assure all parties involved that the panel will operate properly in the event of a break-in.

5.14 Fire, Auxiliary, Panic Keys

The emergency keys are available on all keypads. These keys must be pressed and held for 2 seconds before they will activate. This 2 second delay is designed to help prevent accidental activation.

If the **Fire Keys** option is enabled, when the Fire keys are pressed and held for 2 seconds, the panel will activate the alarm output, pulsing one second on, one second off. If **Fire Bell Continuous** is selected the alarm output will sound until a code is entered, otherwise it will sound until a code is entered or the alarm output times out. Communication of the signal to central station is immediate.

If the **Auxiliary Keys** are pressed and held for 2 seconds the panel will sound the keypad beeper three times to verify activation. The panel will beep the keypad ten times rapidly to verify communication to the central station.

If the **Panic Keys** are pressed and held for 2 seconds, the panel will immediately communicate the signal to central station. If **Panic Keys Audible** is enabled, the panel will beep the keypad three times upon activation and activate the alarm output until a code is entered or the alarm output times out. Otherwise the alarm will be completely silent.

! *The Fire, Auxiliary, Panic keys will operate even if Keypad Blanking is active (See Section 5.23 "Keypad Blanking").*

.....

Fire Keys Enable Section [015], Option [1]

Panic Keys Audible Section [015], Option [2]

Fire Bell Continuous Section [014], Option [8]

.....

5.15 Entry/Exit Delay Options

Upon arming, the panel will begin the exit delay. If **Audible Exit Delay** is enabled the keypad will beep every second until the exit delay expires. The keypad will beep rapidly for the last 10 seconds of exit delay to warn the user the system is about to arm.

For commercial applications **Bell Squawk on Exit Delay** may be enabled. The panel will squawk the alarm output once every second when the exit delay is initiated and 3 times a second for the last 10 seconds until the exit delay expires.

Upon entry, if a Delay type zone is violated, the panel will begin entry delay. The keypad will emit a steady tone. The keypad will pulse the keypad sounder during the last 10 seconds to warn the user the system is about to go into alarm. If there was an alarm during the armed period, the keypad will pulse for the entire entry delay to warn the user of the previous alarm.

For commercial applications **Bell Squawk on Entry Delay** may be enabled. The panel will squawk the alarm output once every second until the entry delay expires or the system is disarmed.

! *Since two Delay zones are programmable, and therefore two different Entry Delays, when the panel is armed it will use the Entry Delay for the first Delay zone violated.*

If **Exit Delay Termination** is enabled the panel will monitor the Delay zones during exit delay. If a Delay type zone is violated then secured during the exit delay, the exit delay will be terminated and the panel will be armed immediately.

.....

Audible Exit Delay	Section [014], Option [6]
Bell Squawk on Exit Delay	Section [014], Option [3]
Exit Delay Termination	Section [014], Option [7]
Bell Squawk on Entry Delay	Section [014], Option [4]

.....

The Audible Exit Delay can help end users avoid the unfortunate experience of creating a false alarm by not exiting quickly enough. The audible beep which increases during the last 10 seconds will help the home owner identify that the delay is about to expire and that they should leave immediately or disarm the system.

In a commercial application the Bell Squawk feature will inform employees the system has been armed, giving them time to disarm the system before a false alarm is generated.

In large installations, where several entry/exit points are present it may be required to program longer exit delay times to allow employees to exit. This may concern some business owners. The Exit Delay Termination feature will remove this obstacle as the panel will end the exit delay when the employee leaves, regardless of which door is used.

5.16 Event Buffer

The panel will store the last 128 events that have occurred on the system. Each event will contain the time, date and the event itself along with the zone number, user code number or any other information pertaining to the event.

If the **Event Buffer Follows Swinger Shutdown** feature is enabled the event buffer will not store events after the swinger shutdown level has been reached. This will prevent the panel from overwriting the entire buffer if a problem exists. (See Section 5.17 "Swinger Shutdown".)

The event buffer can be viewed three different ways. It can be viewed through an LCD keypad, printed on-site using the WSS5400 printer module (See Section 5.29 "On-Site Printer") or it can be uploaded through the DLS software.

5.16.1 Viewing the Event Buffer through the LCD Keypad

The following is the procedure for viewing the event buffer through the LCD keypad:

Step 1 - Enter [*] [6] [Master Code]

Step 2 - Select 'View Event Buffer'

The keypad will display the Event Number, Time and Date of the event in question. Use the [*] key to toggle between this information and the event itself. Use the arrow keys (<->) to scroll through the events in the buffer.

When you have finished viewing the event buffer press the [#] key to exit.

5.16.2 Stored Events

The following is a list of all events that will be stored to the buffer.

[*] indicates the buffer will also store the event occurred.

'XX' indicates the buffer will also store the zone number, user code number or module the event occurred on

- Zone Alarm and Restoral - [*] 'XX'
- Zone Tamper and Restoral - [*] 'XX'
- Zone Trouble and Restoral - [*] 'XX'
- Two Wire Smoke Alarm and Restoral
- Zone Low Battery and Restoral - [*] 'XX'

- Opening and Closing - [*] 'XX'
- Zone Bypass Access - [*] 'XX'
- Partial Closing - [*]
- Stay Arm, Away Arm - [*]
- No Entry Arm - [*] 'XX'
- Zone Bypass - [*] 'XX'
- Reactivate Stay/Away Zones - [*]
- Special Opening and Closing - [*]
- Opening by Keypad and Downloading - [*]
- Closing by Keypad and Downloading - [*]
- Duress - [*] 'XX'
- Opening After Alarm - [*] 'XX'
- Recent Closing - [*]
- Utility Output Activated - [*] 'XX'
- Sensor Reset - [*] 'XX'
- [*], [6] Access - [*] 'XX'
- Keypad Lockout - [*]
- Fire, Auxiliary, Panic Keys Alarm and Restoral - [*] 'XX'

- Periodic, System and LINKS Test Transmission
- Low Battery, AC Power and AUX Output Trouble and Restoral - 'XX'
- Fire Zone Trouble and Restoral - [*] 'XX'
- Bell Circuit Trouble and Restoral
- Telephone Line Trouble and Restoral

- Phone Number 1 and 2 Failure to Communicate and Restoral - [*]
- Installer Lead In and Lead Out
- Downloading (DLS) Lead In and Lead Out
- Event Buffer 75% Full
- Module Tamper Alarm and Restoral - 'XX'
- Module Supervisory Alarm and Restoral - 'XX'
- WSS5400 Module Off and On Line
- KEYBUS Fault and Restoral
- Cold Start and Warm Start
- Default Successful and Default Failed
- Critical Shutdown
- Swinger Shutdown - [*]

.....
 Event Buffer Follows Swinger Shutdown Section [013], Option [7]

The ability to store and retrieve the last 128 events that occurred on the system can be a great tool for troubleshooting the panel in the event of a problem. Being able to view the buffer can help greatly with on-site service and can be a benefit for the customer that wants to view openings and closings but does not want to incur the additional monthly charge.

5.17 Swinger Shutdown

The swinger shutdown feature is designed to prevent a runaway communicator from tying up the central station. Different limits can be programmed for **Zone Alarms**, **Zone Tamper**s and **Maintenance** signals. After the panel has communicated the programmed number of transmissions for an event it will no longer report that event until the swinger shutdown is reset.

For example, the swinger shutdown limit for Zone Alarms is set to [003]. The panel will not send more than 3 alarm signals for each zone with a swinger attribute until the swinger shutdown is reset.

Swinger Shutdown will be reset when the panel is armed or every day at midnight. Once reset, the panel will again communicate normally.

.....
 Swinger Shutdown Limit (Alarms) Section [370]
 Swinger Shutdown Limit (Tamper)s Section [370]
 Swinger Shutdown Limit (Maintenance) Section [370]

5.18 Transmission Delay

If **Transmission Delay** is selected for a zone the panel will delay reporting the alarm for the number of seconds programmed for **Transmission Delay Time**. If the panel is disarmed before the delay time expires the panel will not report the alarm to central station. If the panel is not disarmed in time the panel will communicate normally.

! *This is a global feature.*

.....

Transmission Delay Enable Sections [101] to [132], Option [7]

Transmission Delay Time Section [370]

.....

New customers often cause false alarms while becoming familiar with their alarm system. Programming this feature will help avoid unnecessary false alarms and possibly the unfortunate experience of having the police dispatched. After the customer is familiar with the alarm system the delay can be removed via the DLS Downloading software.

5.19 Keypad Backlighting

The keys of all the keypads can be backlit to provide easy viewing in dim lighting conditions. If the **Keypad Backlighting Option** is enabled the keys will be illuminated.

.....

Keypad Backlighting Option Section [016] - Option [5]

.....

Entering the premises and scrambling for the light switch to help find the keypad creates unnecessary anxiety for the end user. Backlighting will help them find the keypad to disarm the system before a false alarm can be generated.

5.20 Arming /Disarming Options

If the **Arm/Disarm Bell Squawk** option is enabled the panel will squawk the alarm output once upon arming and twice upon disarming. The **Opening After Alarm Keypad Ringback** option will give you the ability to beep the keypad 10 times rapidly if the panel is disarmed after an alarm occurred. The **Opening After Alarm Bell Squawk** option will give you the ability to squawk the bell output 10 times rapidly if the panel is disarmed after an alarm occurred.

Closing Confirmation, if enabled, will cause the keypad to beep 10 times rapidly after the closing reporting code has been transmitted to central station.

.....

Arm/Disarm Bell Squawk Section [014], Option [1]

Opening After Alarm Keypad Ringback Section [381], Option [1]

Opening After Alarm Bell Ringback Section [381], Option [2]

Closing Confirmation Section [381], Option [4]

.....

In a commercial application squawking the siren upon arming can alert someone still in the building to disarm the system, avoiding a false alarm.

Beeping the keypad or squawking the siren when the customer disarms the system after an alarm draws their attention to the fact that an alarm has occurred. They should leave the premises immediately and call central station from a safe location for further instructions.

5.21 Keypad Lockout

The panel can be programmed to 'lockout' keypads if a number of incorrect user code entries are made. After the **Number of Bad Codes Before Lockout** has been reached the panel will lock out the keypad for the **Lockout Duration** and log the event to the event buffer. For the duration of the lockout the panel will sound an error tone when any key is pressed.

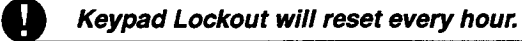

To disable Keypad Lockout program the **Number of Bad Codes Before Lockout** as [000].

- Number of Bad Codes Before Lockout Section [012]
- Lockout Duration Section [012]
- Keypad Lockout Reporting Code Section [338]

This feature can be very useful when trying to identify users having difficulty with the alarm system. If no lockout time is programmed the event will only be stored to the buffer. The buffer can be viewed through the DLS software. If, for example, you find a keypad lockout event followed by a closing or opening event by user #5 it would indicate user #5 had difficulty arming or disarming the system. This individual can be targeted for additional training at a later date.

5.22 Keypad Blanking

If the **Keypad Blanking Option** is enabled the panel will turn off all lights on the keypads except the backlighting of the keys if no key is pressed for 30 seconds.

The panel will turn the lights back on if entry delay begins or an audible alarm occurs. The lights will also come on if a key is pressed or, if the **Code Required to Restore Blanking Option** is enabled, a valid User Code is entered.

If the **Power Save Option** is enabled the panel will blank all keypad lights including backlighting when AC power fails, in order to conserve the back up battery.

- Keypad Blanking Option Section [016], Option [3]
- Code Required to Restore Blanking Section [016], Option [4]
- Power Save Option Section [016], Option [6]

Blanking the keypad is perfect for a keypad located in the bedroom or any application where the backlit keypad may be distracting. In commercial applications where the public have access to the keypad the keypad will not display anything until a valid code is entered avoiding false alarms created by curious people.

5.23 Loop Response

The normal loop response time for all zones is 500 milliseconds. The panel will not consider a zone violated unless it is violated for at least 500 milliseconds.

If **Zone 8 is Fast Loop Response** is enabled the loop response for zone 8 will be 40 milliseconds. Typically this can be used for vibration type sensors.

- Zone 8 is Fast Loop Response Section [013], Option [5]

5.24 LINKS 1000 Cellular Communicator

The LINKS 1000 cellular communicator can be used three different ways; as the sole communicator for the panel, as a back up for either or both phone numbers or as a redundant back up to the land line communicator (the panel will call both the land line and via the LINKS). A **LINKS Preamble** is programmable for each phone number in the event that the land line number is local but the LINKS is required to dial an exchange. When programming a LINKS Preamble, all unused digits must be programmed with a hexa decimal "F".

5.24.1 Using LINKS 1000 as the Sole Communicator

The panel can be programmed to report only using the LINKS 1000 cellular communicator when an event occurs. To program this select only the LINKS 1000 for the **Communicator Call Direction** Options for the event. In addition the **Call LINKS** as well as **Land Line** option must also be enabled.

When the selected event occurs the panel will only attempt to call central station using the LINKS.

5.24.2 Using the LINKS as a Backup Communicator

The panel can be programmed to call using the LINKS 1000 cellular communicator if the panel is having difficulty communicating an event using the land line. To program this select both the phone number and LINKS options for the Communicator Call Direction Options for the event. In addition the LINKS is Backup of Land Lines option must be selected.

When used as a backup communicator the panel attempt to call the central station in the following manner:

- the panel will try to call using land lines - if unsuccessful the panel will try to call using the LINKS
- if unsuccessful the panel will try to call using the land lines
- if unsuccessful the panel will try to call using the LINKS

This process will continue until the panel has successfully communicated with the central station or the **Maximum Dialing Attempts** has been reached.

5.24.3 Using the LINKS as a Redundant Communicator

The panel can be programmed to call using both the land line and the LINKS 1000 cellular communicator when an event occurs. To program this select both the phone number and the LINKS options for the **Communicator Call Direction** Options for the event. In addition the **Call LINKS** as well as **Land Line** option must be selected.

The panel will call the land line and then call using the LINKS when reporting the selected event.

.....

LINKS Preamble (First Telephone Number) Section [390]

LINKS Preamble (Second Telephone Number) Section [391]

LINKS Preamble (Third Telephone Number) Section [392]

LINKS Preamble (Downloading Telephone Number) ... Section [490]

Communicator Call Direction Options Section [361] to [368]

Call LINKS as well as Land Line Section [380], Option [7]

Maximum Dialing Attempts Section [160]

.....

5.25 Wireless Expansion

Any number of zones, up to all 32, can be programmed for wireless. Adding wireless devices to the panel done by simply selecting the zone number and entering the 5 digit ESN number written on the unit.

If the **Zones 1-4 Enable** Option is disabled zones 1 to 4 will be disabled for hardwire operation and wireless devices can be substituted. Also if **Zones 5-8 Enable** Option is disabled zones 5 to 8 will be disabled for hardwire operation and wireless devices can be substituted.

! *Do not add wireless devices to the same zone as a hardwire zone. Hardwire and wireless zones cannot share the same zone.*

Each wireless device will send a supervisory round every 12 minutes. If the receiver hears from the wireless device at least once during the **Wireless Supervisory Window** it will not report a trouble. If the receiver does not it will generate a **General Zone Supervisory** trouble and reporting code. The panel will

not report Supervisory trouble by zone unless the SIA format is used with automatic reporting codes selected (See Section 5.6.3 "SIA").

Within the supervisory transmission the device will also indicate the status of the battery. If a low battery condition exists the panel will indicate a **General Zone Low Battery** trouble. The panel will delay reporting the event for the number of days programmed for **Zone Low Battery Transmission Delay**. If the customer has been instructed on how to replace batteries this will prevent unnecessary reporting of the event provided the batteries are changed.



Important Note

Double End of Line resistors must be enabled in the WSS5010 for the wireless zones to be supervised. If normally Closed or Single EOL resistors are selected the WSS5010 will not be able to supervise the wireless devices.
If a wireless device stops sending a supervisory signal (the unit stops functioning) the panel will not indicate a supervisory trouble condition unless Double EOL supervision is used.
In addition, all hardwire zones must be wired for Double EOL resistors.

5.25.1 Adding Wireless Devices

The following is the method for adding wireless devices to the panel:

- Step 1 - Enter Installer Programming
- Step 2 - Enter Program Section [804]
- Step 3 - Enter the zone number (01 to 32) for the device
- Step 4 - Enter the 5 digit ESN number on the wireless device
- Step 5 - Continue steps [3] and [4] until all wireless devices are added
- Step 6 - Press the [#] key twice to exit Installer Programming

5.25.2 Wireless Device Placement Test

Each wireless detector should be tested before mounting the unit to ensure it will be able to communicate with the receiver from the location selected. The **Wireless Module Placement Test** will allow you to do this. The transmitters will send 4 rounds of information every time the zone is violated or restored.

When testing devices each must be violated and restored to generate a total of 8 signals (2 communications of 4 rounds each). The keypad and siren will indicate the result of the test where:

Placement	LED Keypad	LCD Keypad	Bell/Buzzer
Good	Light 1 On Steady	Good	1 Beep/Squawk
Fair	Light 2 On Steady	Fair	2 Beeps/Squawks
Bad	Light 3 On Steady	Bad	3 Beeps/Squawks



No device should be placed in a location were a Bad test result was indicated.

How to Perform the Wireless Module Placement Test

- Step 1 - Enter Installer Programming
- Step 1 - Enter [*] [8] [Installer Code]
- Step 2 - Enter Program Section [904]
- Step 3 - Enter the two digit zone number for the device to be tested
- Step 4 - **Door Contact** Open and close the contact by moving the magnet or operating the external device connected to the Door Contact. The keypad will display the test result after the zone is restored.
 - **Motion Detectors and Smoke Detectors** Remove the Detector from its backplate, wait for 5 seconds, then reattach the Detector to its backplate. The keypad will display the test result after the Detector is reattached to its backplate.
- Step 5 - The results of the test
- Step 6 - Continue Steps 3 through 5 until all devices have been tested.
- Step 7 - Press the [#] key twice to exit Installer Programming.

5.26 WSS5580 Module

Many consumers will often purchase wants before needs. The alarm system is an identifiable need however rarely is it an item someone wants. The WSS5580 module will help you change the way in which they feel about security.

There are many benefits when adding the WSS5580 module to a security system. The WSS5580 module will turn any touch tone phone in the world into a fully functional keypad. Imagine the security a customer would feel if they had the ability to arm, disarm and check status of the alarm while at the office or on vacation.

In addition, all touch tone phones in the home also become fully functional keypads. This may help reduce the cost of the overall installation because additional keypads (and labour in running wires) can be eliminated.

The WSS5580 will also act as a tutor for the system. By speaking in clear, easy to understand sentences it helps guide a user through functions they may otherwise have difficulty with. Programmable zone labels (up to 6 words each from our library of over 240 words) makes the system even easier to use.

The module also has a built-in power line control interface and can control up to 32 power line control devices for lighting and temperature control, giving you the power to add home automation in a very cost effective manner. Devices can be activated individually, as a group, by schedule or can be activated when an event occurs on the system, such as an alarm.

A portable phone in the family automobile can now be used as a fully functional two way keypad. For example a customer comes home late at night. The house is dark and they have no way of knowing if an alarm occurred while they were out. A portable phone in the car will work from the driveway. The customer now accesses the WSS5580 and in a clear, easy to understand voice they find no alarm occurred. The customer disarms the system and with the power line control turns on a group of lights called 'Home Lighting'. Immediately the lights in the garage, above the front porch and the inside hallway and living room come on. Instead of walking into a dark house with a potential intruder inside they enter a well lit home knowing it is safe.

If an alarm did occur the portable phone can be used to call central station to find out the situation surrounding the alarm condition before they enter the premises or disarm the system.

At bedtime the phone beside the bed can be used to arm the system and with the power line control the customer can turn off a group of lights called 'Night Mode'. Immediately all the lights in the downstairs turn off.

These are just a few applications available with the addition of the WSS5580 module. Additional information can be found in WSS5580 Installation Manual.

5.27 On-Site Printer

The panel, with the addition of the WSS5400 printer module, will print all events as they occur to a local, on-site serial printer. All events printed will include the time, date and the event. For a list of events that will be printed, See Section 5.16 "Event Buffer".

If a problem develops with the printer, such as power loss or paper outage the panel will store events until the problem is corrected, at which point it will print the events from the buffer. The panel can store up to 128 events if such a condition occurs.

.....
WSS5400 Programming Section [801] to [802]
.....

This module will give you the added advantage for the commercial customers who like the idea of a permanent record of openings and closing but are put off by the additional monthly monitoring charge. In addition reports are generated real-time, the customer will not have to wait for a monthly report form the monitoring station.

5.28 Audio Interface Module

The WSS5908 Audio Interface will allow you to connect up to 7 Interior (WSS5903) or exterior (WSS5903EXT) Intercom Stations. These attractive, surface mount stations contain both speaker and microphone and will allow you to add intercom features to your alarm system such as:

- Page/Answer
- Do Not Disturb
- Baby Listener, Broadcast
- Answer Incoming Calls
- Doorbell Function

In addition to these features the module also has built-in two-way voice for central station monitoring. The central station can select the audio station, listen/talk, extend on-line time and hang up.

Each station home-runs to the Audio Interface module using standard 22 gauge, 4 conductor, two pair twist preferred.

For more information regarding the WSS5908 Audio Interface Module refer to the Installation Manual for the product.

5.29 Default (Factory)

On occasion it may be necessary to default the main control panel or one of the modules that can be connected. There are several different defaults available including defaulting the main control panel, WSS5580 module, WSS5132-900 Wireless Expander Module and WSS5400 Printer module.

5.29.1 Factory Default Main Panel (Hardware)

To default the main control panel perform the following:

- Step 1 - Remove AC and battery from the panel.
- Step 2 - Remove all wires from the Zone 1 and PGM1 terminals.
- Step 3 - With a piece of wire short the Zone 1 terminal to the PGM1 terminal.
- Step 4 - Apply AC power to the main panel.
- Step 5 - When Zone Light 1 is lit on the keypad the default is complete.
- Step 6 - Remove AC power from the control
- Step 7 - Reconnect all original wiring and power up the control.

! AC power must be used to power the panel. The panel will not default if the battery is used.

5.29.2 Factory Default Main Panel (Software)

To default the main control perform the following:

- Step 1 - Get into Installer Programming.
- Step 2 - Enter Program Section [999].
- Step 3 - Enter the Installer Code.
- Step 4 - Enter Program Section [999] again.

The panel will take a few seconds to perform the default. When the keypad is again operational the default is complete.

5.29.3 Factory Default WSS5580 Module

To default the WSS5580 module perform the following:

- Step 1 - Get into Installer Programming.
- Step 2 - Enter Program Section [995].
- Step 3 - Enter the Installer Code.
- Step 4 - Enter Program Section [995] again.

The WSS5580 module will take a few seconds to perform the default.

5.29.4 **Factory Default WSS5132-900 Wireless Module**

To default the WSS5132-900 Wireless module perform the following:

Step 1 - Get into Installer Programming.

Step 2 - Enter Program Section [996].

Step 3 - Enter the Installer Code.

Step 4 - Enter Program Section [996] again.

The WSS5132-900 Wireless module will take a few seconds to perform the default.

5.29.5 **Factory Default WSS5400 On-Site Printer Module**

To default the WSS5400 On-Site Printer module perform the following:

Step 1 - Get into Installer Programming.

Step 2 - Enter Program Section [997].

Step 3 - Enter the Installer Code.

Step 4 - Enter Program Section [997] again.

5.29.6 **Factory Default WSS5908 Audio Interface Module**

To default the WSS5908 Audio Interface module perform the following:

Step 1 - Get into Installer Programming.

Step 2 - Enter Program Section [998].

Step 3 - Enter the Installer Code.

Step 4 - Enter Program Section [998] again.

The WSS5908 Audio Interface module will take a few seconds to perform the default.

The WSS5400 On-Site Printer module will take a few seconds to perform the default.

5.30 **Installer Lockout**

If **Installer Lockout** is selected a hardware default cannot be performed. If a software default is performed all programming will restore to factory default.

When **Installer Lockout Disable** is selected the panel will restore all programming to factory defaults, if a hardware or software default is performed on the main control panel.

To enable Installer Lockout perform the following:

Step 1 - Enter Installer Programming

Step 2 - Enter Program Section [990]

Step 3 - Enter the Installer Code.

Step 4 - Enter Program Section [990] again.

To disable Installer Lockout perform the following:

Step 1 - Enter Installer Programming.

Step 2 - Enter Program Section [991].

Step 3 - Enter the Installer Code.

Step 4 - Enter Program Section [991] again.

5.31 Walk Test (Installer)

The Installer Walk Test can be used to verify that each zone of the panel is working. To perform a Walk Test, enter the following:

Step 1 - Enter Installer Programming

Step 2 - Enter Section [901]

When any zone is violated the panel will activate the Bell Output for two seconds, log the event to the Event Buffer and communicate the alarm to central station.

To stop the test, you must do the following:

Step 1 - Enter Installer Programming

Step 2 - Enter Section [901]

Appendix A

S I A F O R M A T

SIA Format

Level 2 (Hardcoded)

The SIA communication format used in this product follows the level 2 specifications of the SIA Digital Communication Standard - February 1993. At the receiver, the transmission would look similar to this example:

N Ri01 BA 01

N = New Event

Ri01 = System

BA = Burglary Alarm

01 = Zone 1

WSS5010 Reporting Codes

SIA Identifiers & Auto-Reporting Code

Zone Alarms & Alarm Restores (Zones 1-32)

Delay Zone Alarm / Restore	BA-XX / BH-XX	Zone Number is Identified
Instant Zone Alarm / Restore	BA-XX / BH-XX	Zone Number is Identified
Interior Zone Alarm / Restore	BA-XX / BH-XX	Zone Number is Identified
Delay H.A. Zone Alarm / Restore	BA-XX / BH-XX	Zone Number is Identified
Interior H.A. Zone Alarm / Restore	BA-XX / BH-XX	Zone Number is Identified
24 Hr Burg Zone Alarm / Restore	BA-XX / BH-XX	Zone Number is Identified
Standard Fire Zone Alarm / Restore	FA-XX / FH-XX	Zone Number is Identified
Delayed Fire Zone Alarm / Restore	FA-XX / FH-XX	Zone Number is Identified
24 Hr Supervisory Buzzer Zone Alarm / Restore	UA-XX / UH-XX	Zone Number is Identified
24 Hr Supervisory Zone Alarm / Restore	UA-XX / UH-XX	Zone Number is Identified
24 Hr Medical Zone Alarm / Restore	MA-XX / MH-XX	Zone Number is Identified
24 Hr Panic Zone Alarm / Restore	PA-XX / PH-XX	Zone Number is Identified
24 Hr Holdup Zone Alarm / Restore	HA-XX / HH-XX	Zone Number is Identified
24 Hr Gas Zone Alarm / Restore	GA-XX / GH-XX	Zone Number is Identified
24 Hr Heat Zone Alarm / Restore	KA-XX / KH-XX	Zone Number is Identified
24 Hr Emergency Zone Alarm / Restore	QA-XX / QH-XX	Zone Number is Identified
24 Hr Sprinkler Zone Alarm / Restore	SA-XX / SH-XX	Zone Number is Identified
24 Hr Water Zone Alarm / Restore	WA-XX / WH-XX	Zone Number is Identified
24 Hr Freeze Zone Alarm / Restore	ZA-XX / ZH-XX	Zone Number is Identified
24 Hr Latching Tamper Alarm / Restore	BA-XX / BH-XX	Zone Number is Identified
Duress Alarm	HA-00	
Opening After Alarm	OR-00	
Recent Closing	CR-00	
Zone Expander Supervisory Alarm / Restore	UA-00 / UH-00	
Keypad Fire Alarm / Restore	FA-00 / FH-00	
Keypad Auxiliary Alarm / Restore	MA-00 / MH-00	
Keypad Panic Alarm / Restore	PA-00 / PH-00	
2-Wire Smoke Alarm / Restore	FA-00 / FH-00	
Zone Tamper (1-32)	TA-XX	Zone Number is Identified
Zone Tamper Restorals (1-32)	TR-XX	Zone Number is Identified

WSS5010 Reporting Codes

**SIA Identifiers &
Auto-Reporting Code**

**Zone Alarms & Alarm Restores
(Zones 1-32)**

General System Tamper / Restore	TA-00 / TR-00	
Keypad Lockout	JA-00	
Closing By Access Codes 1-32,33,34,40,41,42	CL-XX	User Number is Identified
Partial Closing	CG-XX	Each Zone Number is Identified (using UB-XX)
Special Closing (DLS, Keys, Maint, Quick)	CL-00	
Opening By Access Codes 1-32,33,34,40,41,42	OP-XX	User Number is Identified
Special Opening (DLS, Keys, Maint)	OP-00	
Battery Trouble Alarm / Restore	YT-00 / YR-00	
AC Failure Trouble Alarm / Restore	AT-00 / AR-00	
Bell Circuit Trouble Alarm / Restore	UT-99 / UJ-99	
Fire Trouble Alarm / Restore	FT-00 / FJ-00	
Auxiliary Power Supply Trouble Alarm / Restore	YP-00 / YQ-00	
TLM Trouble Code (via LINKS)	LT-00	
General System Trouble / Restore	YX-00 / YZ-00	
General System Supervisory / Restore	ET-00 / ER-00	
TLM Restoral	LR-00	
FTC Restoral	YK-00	
Event Buffer 75% Full Since Last Upload	JL-00	
DLS Lead IN	RB-00	
DLS Lead Out (Successful)	RS-00	
Periodic Test Transmission	RP-00	
System Test	RX-00	
LINKS1000 Test Transmission Code	TX-00	
General Transmitter Low Battery / Restore	XT-00 / XR-00	Zone Number is Identified
General Zone Trouble / Restore	UT-00 / UJ-00	Zone Number is Identified

Appendix B

HOW TO PROGRAM THE LCD KEYPAD

How to Program the LCD Keypad

If you have an WSS5500 LCD Keypad additional programming is required for proper operation. The following is a description of the programming options available:

How to Enter LCD Programming

Step 1 - Press [*], [8], [Installer Code] (Enter Installer Programming)

Step 2 - Press the [*] key

Step 3 - Enter the 2 digit Section number to program.

Follow the programming procedure as outlined in Section 4 - How To Program.

The Programming Worksheets for the LCD5500 keypad can be found in the back of the Programming Worksheets manual.

Programmable Zone Labels - Section [01] to [32]

Default for each zone label is simply 'Zone 1' to 'Zone 32'. These labels can be changed to make operation of the system easier for the end user. The following is the procedure for changing zone labels:

Step 1 - Enter Installer Programming.

Step 2 - Enter the Zone Number for the Label to Program (Section [01] to [32]).

Step 3 - Use the arrow keys (<>) to move the underline bar underneath the letter to be changed.

Step 4 - Press the number key [1] to [9] corresponding to the letter you require. The first time you press the number the first letter will appear. Pressing the number key again will display the next letter. Refer to the following chart:

[1] - A, B, C, 1	[2] - D, E, F, 2	[3] - G, H, I, 3	[4] - J, K, L, 4	[5] - M, N, O, 5
[6] - P, Q, R, 6	[7] - S, T, U, 7	[8] - V, W, X, 8	[9] - Y, Z, 9,0	[0] - Space

Step 5 - When the required letter or number is displayed use the arrow keys (<>) to scroll to the next letter.

Step 6 - When you are finished programming the Zone Label press the [*] key and scroll to "Save" then press the [*] key again.

Step 7 - Continue from Step 2 until all Zone Labels are programmed.

Utility Output Labels - Section [40] and [41]

A custom label can be programmed for any PGM Output programmed as 'Utility Output' (See Section 5.10 "PGM Outputs"). When the output is activated the custom message will be displayed for 5 seconds. Follow the procedure outlined for programming Zone Labels to program Utility Output Labels.

Sensor Reset Labels - Section [44] and [45]

A custom label can be programmed for any PGM Output programmed as 'Sensor Reset' (See Section 5.10 "PGM Outputs"). When the output is activated the custom message will be displayed for 5 seconds. Follow the procedure outlined for programming Zone Labels to program Sensor Reset Labels.

Fail to Arm Message - Section [51]

If the panel is unable to arm because a zone is violated (the system is not Ready) a custom message can be displayed for 5 seconds to alert the user the system has not armed. Follow the procedure outlined for programming Zone Labels to program the Fail to Arm Label.

Alarm When Armed Message - Section [52]

If an alarm occurred while the panel was armed a custom message can be displayed for 5 seconds when the user disarms the system. Follow the procedure outlined for programming Zone Labels to program the Alarm When Armed Label.

User Display Options - Section [60] to [62]

A times it may be necessary to remove certain options or features from the keypad display to prevent users from knowing about the features or to make the system easier to operate. For example, if Automatic Arming is not being used on an installation it may be useful to remove the Automatic Arming options from being displayed on the keypad. This will help avoid end user confusion or questions.

Toggle options on or off in these Sections to enable or disable messages from being displayed.



Note that although the message is not displayed in the menu pressing the correct key will still give access to the feature for service personnel.

Download Message Duration - Section [63]

Messages can be downloaded to the LCD keypads. The three digit number in this Section represents the number of keypresses the user must make to remove the message. To have the message constantly display enter [000].

Fire, Auxiliary, Panic Keys Options - Section [64]

This Section will allow you to specify which of the Fire, Auxiliary, Panic keys function on the LCD keypads. This is a done by keypad, the options must be turned on or off at each keypad.

Keypad Options - Section [64]

This Section will allow you to select if the time and date are displayed on the LCD keypad. In addition, when User Codes are being programmed the option of displaying the code or having 'X's appear is an option.

Initiate Global Label Broadcast - Section [98]

All LCD programming is done by keypad. If more than one LCD keypad is present it is not necessary to program each independently. Labels programmed in one keypad can be broadcast to all other LCD keypads. The following is the procedure for broadcasting labels:

- Step 1 - Program one LCD keypad completely.
- Step 2 - Make sure all LCD keypads are connected to the KEYBUS.
- Step 3 - Enter Installer Programming at the keypad that was programmed.
- Step 4 - Enter Section [98] at the keypad that was programmed.
The keypad will now broadcast all the information programmed to all the other LCD keypads on the system.
- Step 5 - When the keypad is finished press the [#] key to exit.

Factory Default LCD Keypad - Section [99]

At times it may be necessary to restore an LCD keypad back to factory default. The following is the procedure for factory defaulting an LCD keypad:

- Step 1 - Enter Installer Programming at the keypad to be defaulted.
 - Step 2 - Enter Section [99] at the keypad to be defaulted.
- When the keypad is finished defaulting press the [#] key to exit programming.

Appendix C

LIST OF AVAILABLE ASCII CHARACTERS

List of Available ASCII Characters

032	048	064	080	096	112	160	176	192	208	224	240
!	1	A	Q	á	Ɔ	◻	Ɔ	Ɔ	◻	ä	q
033	049	065	081	097	113	161	177	193	209	225	241
"	2	B	R	b	Ɔ	Ɔ	Ɔ	Ɔ	Ɔ	Ɔ	Ɔ
034	050	066	082	098	114	162	178	194	210	226	242
#	3	C	S	c	s	Ɔ	Ɔ	Ɔ	Ɔ	Ɔ	Ɔ
035	051	067	083	099	115	163	179	195	211	227	243
\$	4	D	T	d	t	Ɔ	Ɔ	Ɔ	Ɔ	Ɔ	Ɔ
036	052	068	084	100	116	164	180	196	212	228	244
%	5	E	U	e	u	•	Ɔ	Ɔ	Ɔ	Ɔ	Ɔ
037	053	069	085	101	117	165	181	197	213	229	245
&	6	F	V	f	v	Ɔ	Ɔ	Ɔ	Ɔ	Ɔ	Ɔ
038	054	070	086	102	118	166	182	198	214	230	246
'	7	G	W	g	w	Ɔ	Ɔ	Ɔ	Ɔ	Ɔ	Ɔ
039	055	071	087	103	119	167	183	199	215	231	247
(8	H	X	h	x	Ɔ	Ɔ	Ɔ	Ɔ	Ɔ	Ɔ
040	056	072	088	104	120	168	184	200	216	232	248
)	9	I	Y	i	y	Ɔ	Ɔ	Ɔ	Ɔ	Ɔ	Ɔ
041	057	073	089	105	121	169	185	201	217	233	249
*	:	J	Z	j	z	Ɔ	Ɔ	Ɔ	Ɔ	Ɔ	Ɔ
042	058	074	090	106	122	170	186	202	218	234	250
+	;	K	[k	[Ɔ	Ɔ	Ɔ	Ɔ	Ɔ	Ɔ
043	059	075	091	107	123	171	187	203	219	235	251
,	<	L	¥	l	l	Ɔ	Ɔ	Ɔ	Ɔ	Ɔ	Ɔ
044	060	076	092	108	124	172	188	204	220	236	252
-	=	M]	m]	Ɔ	Ɔ	Ɔ	Ɔ	Ɔ	Ɔ
045	061	077	093	109	125	173	189	205	221	237	253
•	>	N	^	n	^	Ɔ	Ɔ	Ɔ	Ɔ	Ɔ	Ɔ
046	062	078	094	110	126	174	190	206	222	238	254
/	?	O	_	o	_	Ɔ	Ɔ	Ɔ	Ɔ	Ɔ	Ɔ
047	063	079	095	111	127	175	191	207	223	239	255

Index

Section

*	[*] Commands	3.4
	<i>Code Required for Bypass</i>	Section [015], Option [5]
	<i>Master Code Not Changeable Option</i>	Section [015], Option [6]
	<i>Quick Exit Enable</i>	Section [015], Option [3]
A	Access Codes	3.1
	<i>System Master Code Not Changeable</i>	Section [015], Option [6]
	<i>System Master Code</i>	Section [007]
	Programming	3.4
	Additional Devices	1.3
	Keypads	1.3.1
	WSS5108 Eight Zone Expander Module	1.3.2
	WSS5132-900 Wireless Receiver Module	1.3.3
	WSS5204 Power Supply Output Module	1.3.4
	WSS5208 Eight Low Current Output Module	1.3.5
	WSS5580 Module	1.3.6
	WSS5908 Audio Interface Module	1.3.7
	WSS5400 Printer Module	1.3.8
	LINKS 1000 Cellular Communicator	1.3.9
	Cabinets	1.3.10
	Backplates	1.3.11
	Alarm Memory	3.4
	Arming	3.2
	Arming/Disarming Options	5.20
	<i>Arm/Disarm Bell Squawk</i>	Section [014], Option [1]
	<i>Opening After Alarm Keypad Ringback</i>	Section [381], Option [1]
	<i>Opening After Alarm Bell Ringback</i>	Section [381], Option [2]
	<i>Closing Confirmation</i>	Section [381], Option [4]
	Arming Without Entry Delay	3.4
	Assigning Zones to Zone Expanders	2.4
	Attributes	5.2
	Audio Interface Module	5.30
	Away Arm	3.5
B	Burglary Zone, 24 Hour	5.1
	Bypass	3.4
	Bypass Enable	5.2
C	Communicator - System Identifier Code	5.5
	<i>System Identifier Code</i>	Section [310]
	Communicator - Dialing	5.3
	<i>Pulse Dialing</i>	Section [380], Option [3]
	<i>Switch to Pulse Dial</i>	Section [380], Option [4]
	<i>Post Dial Wait for Handshake</i>	Section [161]
	<i>Maximum Dialing Attempts</i>	Section [160]
	<i>Communicator Disable</i>	Section [380], Option [1]
	<i>Communicator Call Direction Options</i>	Section [361] to [368]
	Communicator - Phone Numbers	5.4
	<i>1st Phone Number</i>	Section [301]
	<i>2nd Phone Number</i>	Section [302]
	<i>3rd Phone Number</i>	Section [303]
	<i>3rd Phone Number Enable</i>	Section [380], Option [5]
	<i>Alternate Dial</i>	Section [380], Option [6]

	Section
Communicator - Reporting Formats	5.6
SIA	5.6.1
Pager Format	5.6.2
Communicator Format Options	Section [360]
Communicator Call Direction Options	Section [361] to [368]
SIA Sends Programmed Reporting Codes	Section [380], Option [3]
Communicator - Reporting Codes	5.7
Zone Alarm Reporting Codes	Section [320] to [323]
Zone Restoral Reporting Codes	Section [324] to [327]
Closing Reporting Codes	Section [328], [339] to [343]
Opening Reporting Codes	Section [328], [344] to [348]
Tamper Alarm Reporting Codes	Section [330] to [333]
Tamper Restoral Reporting Codes	Section [334] to [337]
Maintenance Alarm Reporting Codes	Section [349]
Maintenance Restoral Reporting Codes	Section [350]
Priority Alarm/Restoral Reporting Codes	Section [329]
Miscellaneous Reporting Codes	Section [338], [351]
Test Transmission Reporting Codes	Section [352]
Wireless Maintenance Reporting Codes	Section [353]
Confirming Modules	2.7
D Date and Time	3.4
Decimal Data	4.2
Default (Factory)	5.29
Factory Default Main Panel (Hardware)	5.29.1
Factory Default Main Panel (Software)	5.29.2
Factory Default WSS5580 Module	5.29.3
Factory Default WSS5132-900 Wireless Module	5.29.4
Factory Default WSS5400 Printer Module	5.29.5
Factory Default WSS5908 Audio Interface Module	5.29.6
Delay 1 Zone	5.1
Delay 2 Zone	5.1
Delay Stay/Away	5.1
Delayed 24 Hour Fire Zone	5.1
Delayed 24 Hour Fire Zone (Wireless)	5.1
Deleting Modules	2.8
Disarming	3.3
Door Chime	3.4
Door Strike	3.4
Downloading	5.8
Downloading Answer	Section [401], Option [1]
User Enable DLS Window	Section [401], Option [2]
Call Back	Section [401], Option [3]
Answering Machine Double Call Timer	Section [405]
Downloading Computer Telephone Number	Section [402]
Downloading Access Code	Section [403]
Panel Identifier	Section [404]
LINKS 1000 Preamble (Downloading)	Section [490]
Duress Code	3.1
E Emergency Zone, 24 Hour	5.1
Enable DLS (Downloading)	3.4
Enable Supervision	2.6
Enrolling Modules	2.7
Entry/Exit Delay Options	5.15
Audible Exit Delay	Section [014], Option [6]
Bell Squawk on Exit Delay	Section [014], Option [3]
Exit Delay Termination	Section [014], Option [7]
Bell Squawk on Entry Delay	Section [014], Option [4]

	Section
Event Buffer	5.16
Viewing through LCD Keypad	5.16.1
Stored Events	5.16.2
F	
Fast Loop Response	5.24
Features and Specifications	1.1
Fire Zone	5.1
Fire, Auxiliary, Panic Keys	5.14
<i>Fire Keys Enable</i>	<i>Section [015], Option [1]</i>
<i>Panic Keys Audible</i>	<i>Section [015], Option [2]</i>
<i>Fire Bell Continuous</i>	<i>Section [014], Option [8]</i>
Freezer Zone, 24 Hour	5.1
Function Keys	3.5
G	
Gas Zone, 24 Hour	5.1
Glossary	1.2
H	
Heat Zone, 24 Hour	5.1
HEX Data	4.3
Holdup Zone, 24 Hour	5.1
How to Enter Installer Programming	4.1
I	
Installation Tips	2.1
Installer Lockout	5.29
Installer Programming	3.4
Instant Zone	5.1
Interior Zone	5.1
Interior Stay/Away	5.1
J	
Jumper Settings, Zone Expanders	2.5
Jumper Settings, Main Panel	2.8.4
K	
KEYBUS Operation and Wiring	2.3
Keypad Assignment	2.5
How To Assign Keypads	2.5.1
How To Program Function Keys	2.5.2
Keypad Backlighting	5.19
<i>Keypad Backlighting Option</i>	<i>Section [016], Option [5]</i>
<i>Trouble LED Flashes if AC Fails</i>	<i>Section [016], Option [2]</i>
Keypad Blanking	5.22
<i>Keypad Blanking Option</i>	<i>Section [016], Option [3]</i>
<i>Code Required to Restore Blanking</i>	<i>Section [016], Option [4]</i>
<i>Power Save Option</i>	<i>Section [016], Option [6]</i>
Keypad Lockout	5.21
<i>Number of Bad Codes Before Lockout</i>	<i>Section [012]</i>
<i>Lockout Duration</i>	<i>Section [012]</i>
Keypad Operation	3.6
Keyswitch Arming	5.1

Section

L

- Latching Tamper Zone, 24 Hour 5.1
- LINKS 1000 Cellular Communicator 5.24
 - Using LINKS 1000 as the Sole Communicator 5.24.1
 - Using LINKS 1000 as a Backup Communicator 5.24.2
 - Using LINKS 1000 as a Redundant Communicator 5.24.3
 - LINKS Preamble (1st Telephone Number) Section [390]
 - LINKS Preamble (2nd Telephone Number) Section [390]
 - LINKS Preamble (3rd Telephone Number) Section [390]
 - LINKS Preamble (Downloading Telephone Number) Section [490]
 - Communicator Call Direction Options Section [361] to [368]
 - Call LINKS as well as Land Line Section [380], Option [7]
 - Maximum Dialing Attempts Section [160]
- LINKS Answer Zone 5.1
- Loop Response 5.23
 - Zone 8 is Fast Loop Response Section [013], Option [5]

M

- Maintained Keyswitch Arming 5.1
- Master Code 3.1
- Medical Zone, 24 Hour 5.1
- Module 1.3
- Module Supervision 2.7
- Momentary Keyswitch Arm Zone 5.1

N

- No-Entry Delay Arm 3.4
- Null Key 3.5
- Null Zone 5.1

O

- On-Site Printer 5.27
 - WSS5400 Programming Section [801] to [802]
- Out of the Box 1.4

P

- Panic Zone, 24 Hour 5.1
- PGM Outputs 5.10
 - PGM Output Options 5.10.1
 - PGM Output Attributes 5.10.2
 - Main Board PGM Outputs Section [009]
 - WSS5208 PGM Outputs Section [010]
 - WSS5204 PGM Outputs Section [011]
 - PGM1 (Main Board) Output Attributes Section [141]
 - PGM2 (Main Board) Output Attributes Section [142]
 - WSS5208 PGM Output Attributes Section [143] to [150]
 - WSS5204 PGM Output Attributes Section [151] to [154]
 - Burglary and Fire Bell Output Section [009],[010] and [011], Option [01]
 - Utility Output Section [009],[010] and [011], Option [02]
 - Sensor Reset Section [009],[010] and [011], Option [03]
 - 2-Wire Smoke Reset (PGM2 Only) Section [009], Option [04]
 - System Armed Status Section [009],[010] and [011], Option [05]
 - Ready Output Section [009],[010] and [011], Option [06]
 - Keypad Buzzer Follow Section [009],[010] and [011], Option [07]
 - Courtesy Pulse Section [009],[010] and [011], Option [08]
 - System Trouble Section [009],[010] and [011], Option [09]
 - Latched System Event (Strobe) Section [009],[010] and [011], Option [10]
 - System Tamper Section [009],[010] and [011], Option [11]
 - TLM and Alarm Section [009],[010] and [011], Option [12]
 - Kissoff Output Section [009],[010] and [011], Option [13]
 - Ground Start Pulse Section [009],[010] and [011], Option [14]
 - Remote Operation (DLS-1 Support) Section [009],[010] and [011], Option [15]
 - LINKS 1000 Support (PGM1 Only) Section [009], Option [16]

	Section
Printer	5.29
Programming Decimal Data	4.2
Programming HEX Data	4.3
Programming, How to Enter	4.1
Programming Toggle Option Sections	4.4
Programming, Viewing	4.5
Q Quick Exit	3.4
R Reactivate Stay/Away Zones	3.4
Removing Modules	2.7
Reset Smoke Detectors	3.4
Ring Detect	5.8
S Siren Supervision	5.12
<i>Bell Circuit Trouble Reporting Code</i>	Section [349]
<i>Bell Circuit Trouble Restoral Reporting Code</i>	Section [350]
Smoke Detector Reset	3.4
Sprinkler Zone, 24 Hour	5.1
Standard 24 Hour Fire Zone	5.1
Standard 24 Hour Fire Zone (Wireless)	5.1
Stay/Away	3.3 & 5.1
Stay Arm	3.5
Supervisory Buzzer Zone, 24 Hour	5.1
Supervisory Zone, 24 Hour	5.1
Swinger Shutdown	5.17
<i>Swinger Shutdown Limit (Alarms)</i>	Section [370]
<i>Swinger Shutdown Limit (Tampers)</i>	Section [370]
<i>Swinger Shutdown Limit (Maintenance)</i>	Section [370]
<i>Event Buffer Follows Swinger Shutdown</i>	Section [013], Option [7]
Swinger Shutdown Enable	5.2
System Test	3.4
T Tamper Zone, 24 Hour Latching	5.1
Telephone Line Monitor (TLM)	5.11
<i>TLM Enable/Disable</i>	Section [015], Option [7]
<i>TLM Trouble Only or Audible When Armed</i>	Section [015], Option [8]
<i>TLM Trouble Delay</i>	Section [370]
<i>TLM Trouble Reporting Code</i>	Section [349]
<i>TLM Restoral Reporting Code</i>	Section [350]
Terminal Description	2.2
Test Transmission	5.13
<i>Periodic Test Transmission Reporting Code</i>	Section [352]
<i>Test Transmission Time of Day</i>	Section [371]
<i>Test Transmission Cycle</i>	Section [370]
<i>Links 1000 Test Transmission Reporting Code</i>	Section [352]
<i>System Test Reporting Code</i>	[352]
Time and Date	3.4
Toggle	4.4
Transmission Delay	5.18
<i>Transmission Delay Enable</i>	Section [101] to [132], Option [7]
<i>Transmission Delay Time</i>	Section [370]
Trouble Display	3.4

Section

U	User Codes	3.1
	User Functions	3.4
	Utility Output Functions	3.4
V	View Alarm Memory	3.4
	View Trouble	3.4
	Viewing Programming	4.5
W	Walk Test (Installer)	5.31
	Waterflow Zone, 24 Hour	5.1
	Wireless Expansion	5.25
	Adding Wireless Devices	5.25.1
	Wireless Device Placement Test	5.25.2
	Wireless Fire Zone	5.1
	WSS5580 Module	5.26
Z	Zone Assignments	5.9
	Zone Assignments	Section [202] to [205]
	Zone Attributes	5.2
	Zones 1 to 32 Attributes	Section [101] to [132]
	Audible/Silent Alarm	Section [101] to [132], Option [1]
	Pulsed/Steady Alarm	Section [101] to [132], Option [2]
	Activate Chime	Section [101] to [132], Option [3]
	Bypass Enable	Section [101] to [132], Option [4]
	Swinger Shutdown Enable	Section [101] to [132], Option [6]
	Transmission Delay Enable	Section [101] to [132], Option [7]
	Zone Definitions	5.1
	Zone Loop Response	5.23
	Zone Wiring	2.8
	Normally Closed (NC) Loops	2.8.1
	Single End Of Line (EOL) Resistors	2.8.2
	Double EOL Resistors	2.8.3
	Fire Zone Wiring - 4 Wire Smoke Detectors	2.8.4
	Fire Zone Wiring - 2 Wire Smoke Detectors	2.8.5
	Keyswitch Zone Wiring	2.8.6
	LINKS Supervisory	2.8.7
	Links Answer	2.8.8

UL Listed Commercial and Residential Installations

The installation requirements listed below must be met for the following grades of service.

Grade A Local

The installation must have a bell UL Listed for mecatile local alarms (AMSECO MBL 10B with Model AB-12 bell housing).

The digital communicator must be enabled.

The control panel must be in the Attack Resistant Enclosure (DSC Model CMC-1).

Grade B Central Station and Police Connect

The installation must have a bell UL Listed for mecatile local alarms (AMSECO MBL10B with Model AB-12 bell housing).

The digital communicator must be enabled.

The control panel must be in the Attack Resistant Enclosure (DSC Model CMC-1).

Grade C Central Station

The digital communicator must be enabled.

The control panel must be in the Attack Resistant Enclosure (DSC Model CMC-1).

All Commercial Installations

- The entry delay must not exceed 60 seconds
- The exit delay must not exceed 60 seconds.
- The minimum bell cutoff time is 15 minutes.

Residential Installations

- The entry delay must not exceed 45 seconds
- The exit delay must not exceed 60 seconds.
- The minimum bell cutoff time is 4 minutes.

Programming

The notes in the programming sections describing the system configurations for UL Listed installations must be implemented.

Control of the Protected Premises

In order to have a UL Certificated system the protected area is to be under the responsibility of one ownership and management (i.e. one business under one name). This may be a group of buildings attached or unattached with different addresses but under the responsibility of someone having mutual interest. The person of mutual interest is not the alarm installing company.

Bell Location

The alarm sounding device (bell) must be located where it can be heard by the person or persons responsible for maintaining the security system during the daily arming cycle.

Protection of the Control Unit

The local control and the local power supply must be protected by one of the following ways:

- The control unit and audible alarm device must be in a protected area which is armed 24 hours a day.
- Each partition shall arm the area protecting the control unit and the audible alarm device power supply. This may require duplicate protection armed by each partition. Access to this protected area, without causing an alarm, will require that all partitions be disarmed.

In all cases described above, the protected area for the control unit must be programmed as not bypassable.

Casual Users

The installer should caution the user(s) to not give system information to casual users (e.g. codes, bypass methods, etc. to baby-sitters or service people). Only the One-Time Use codes should be given to casual users.

User Information

The installer should advise the users and note in the user instruction manual:

- Service organization name and telephone number
- The programmed exit time
- The programmed entry time

UL Listing

This product is UL Listed in file S4019.

Listed Models	Equivalent WSS Models
PC5010	WSS5010
PC5508/KP5508/P832-08	WSS5508
PC5516/KP5516/P832-16	—
PC5532/KP5532/P832-32	—
LCD5500/KPL5500/P832-LCD	WSS5500
PC5108	WSS5108
PC5208	WSS5208

Any product or accessory not in the above list was not UL Listed at the time of manufacture.



Westinghouse Security Systems
1-800-SMART 20